

# Edel EAU

## Domestic hot water heat pump

Using calories drawn from the return flow of underfloor heating



### Installation manual



The information contained in this document is non-contractual. We reserves the right to modify the technical specifications or characteristics of any of their appliances without prior notice.

**Edel 200 EAU/3**  
Ref. 352421

**Edel 270 EAU/3**  
Ref. 352431



BVCert. 6020118

**Made in  
France**



Manual ref: 1898865  
Edition n°: 24.06

# TABLE OF CONTENTS

<b>1 - SAFETY .....</b>	<b>3</b>
<b>2 - RECOMMENDATIONS .....</b>	<b>5</b>
2.1 - Storage .....	5
2.2 - Transport.....	5
2.3 - Handling .....	6
2.4 - Contents of packaging.....	6
2.5 - Unpacking .....	6
2.6 - Symbols used .....	7
<b>3 - OPERATING PRINCIPLE .....</b>	<b>7</b>
<b>4 - INTRODUCTION .....</b>	<b>8</b>
4.1 - Dimensions .....	8
4.2 - EU declaration.....	8
4.3 - Technical specifications and performances .....	8
<b>5 - INSTALLATION.....</b>	<b>9</b>
5.1 - Placement and positioning.....	9
5.1.1 - Placement choice .....	9
5.1.2 - Positioning and anchoring.....	9
5.1.3 - Options.....	10
5.1.3.1 - Primary circuit mixing valve.....	10
5.1.4 - Included accessory.....	10
5.1.4.1 - Hydraulic derivation module.....	10
5.2 - Hydraulic connections to the underfloor heating circuit....	10
5.2.1 - Underfloor heating derivation module.....	10
5.2.1.1 - Description.....	10
5.2.1.2 - Underfloor heating derivation module circulator .....	10
5.2.2 - Filter.....	10
5.2.3 - Radiators.....	10
5.2.4 - Minimum surface area for underfloor heating.....	10
5.2.5 - 3-way mixing valve for underfloor heating circuit.....	11
5.2.6 - Thermostatic mixing valves equipping the water loops of the underfloor heating circuit.....	12
5.2.7 - Underfloor heating circuit circulator.....	12
5.2.8 - Treatment of the water in the heating circuit.....	12
5.2.9 - Filling water .....	12
5.2.10 - Treatment of the heating circuit.....	12
5.2.11 - Purging the installation .....	13
5.3 - Connection to the domestic water supply.....	13
5.4 - Electrical connections.....	14
5.4.1 - Remove the top cover.....	15
5.4.2 - External control .....	15
5.4.2.1 - Peak / Off-peak hours contact .....	15
5.4.2.2 - Electricity provider contact .....	15
5.4.2.3 - Connection to the photovoltaic (PV) function.....	16
<b>6 - SET-UP AND USE .....</b>	<b>17</b>
6.1 - Control panel.....	17
6.2 - Setting the language.....	17
6.3 - Setting the date and time.....	18
6.4 - Setting the desired water temperature .....	18
6.4.1 - PV mode deactivated.....	18
6.4.2 - PV mode activated .....	18
6.5 - Holiday/temporary standby mode.....	19
6.6 - BOOST mode (for occasional use and guaranteed comfort).....	19

6.7 - Electric mode (for operation using only the electrical back-up).....	19
6.8 - Programming .....	19
6.9 - INSTALLER menu .....	20
6.9.1 - PV mode.....	20
6.9.2 - PERF mode.....	20
6.9.3 - Setting the operating parameters.....	20
6.9.3.1 - <b>ANTI-BACT</b> Anti-legionellosis cycle .....	21
6.9.3.2 - <b>T°C. MINI</b> Minimum temperature.....	21
6.9.3.3 - <b>LOAD SHEDDING</b> Level of operation authorised during peak time.....	21
6.9.3.4 - <b>MAX TIME</b> Max heating time.....	21
6.9.3.5 - <b>TEMP MIN</b> Low temperature .....	21
6.9.4 - Locking the keyboard .....	23
6.9.5 - Resetting the parameters .....	23
6.9.6 - Reading data .....	23
6.9.7 - Counters.....	23

## 7 - MAINTENANCE AND TROUBLESHOOTING 24

7.1 - Water circuit.....	24
7.2 - Water circuit for return flow from underfloor heating .....	24
7.3 - Electrical maintenance .....	24
7.4 - Drainage.....	25
7.5 - Modification.....	25
7.6 - Decommissioning.....	25
7.6.1 - Leak detection .....	25
7.6.2 - Removal and evacuation .....	25
7.6.3 - Charging process.....	25
7.6.4 - Decommissioning .....	25
7.6.5 - Recovery .....	26
7.6.6 - Recycling and Disposal.....	26
7.7 - Troubleshooting.....	27
7.8 - NTC sensor data.....	27
7.9 - List of spare parts.....	28
7.10 - Error message codes: errors, solutions and operating in case of error .....	29

## 8 - WARRANTY ..... 30

8.1 - Limitations of warranty.....	30
8.1.1 - General information .....	30
8.1.2 - Exclusion from warranty .....	30
8.1.2.1 - Use.....	30
8.1.2.2 - Handling.....	30
8.1.2.3 - Placement.....	30
8.1.2.4 - Electrical connections .....	30
8.1.2.5 - Hydraulic connections .....	30
8.1.2.6 - Accessories.....	30
8.1.2.7 - Maintenance.....	30

## 9 - APPENDIX ..... 31

9.1 - Wiring diagram .....	31
----------------------------	----

### Preserving these documents

- This manual and all other relevant documents should be given to the system user.
- The system user should keep these manuals for future reference.

## 1 - SAFETY



• **Any intervention on the thermodynamic water heater should only be performed by qualified personnel.**

- **Follow the safety instructions!**
- **Any intervention on the refrigeration circuit must be made by a qualified person who holds a Category 1 certificate of fitness. Refrigerant R290, contained in the heat pump circuit, does not pose an environmental hazard but is flammable.**
  - Refrigerant R290 is odorless,
  - Do not damage the refrigeration circuit tubes,
  - Do not handle flame or other flammable sources inside the device,
  - in the event of a leakage of the refrigerant, unplug the plug, ventilate the room and contact the customer service,
  - Do not pierce or burn the appliance: the recovery of the fluid is mandatory in case of intervention on the refrigeration circuit.

### Danger of death by electrocution

Touching live electrical wires can cause severe injury.

- Before undertaking any work on the appliance, ensure to switch off the power supply to the appliance.
- Ensure that there is no possibility of the power supply becoming active again.

### Danger of injury or death due to the absence of, or defective, safety devices.

Absence of safety devices can be dangerous and may result in burns or other injuries. Injuries could be caused by pipes bursting for example.

The information provided in this document does not represent all of the diagrams required for a professional installation of the safety devices.

- Install all required safety devices in the circuit.
- Inform the user of where the safety devices are placed, and how they work.
- Follow all relevant national and international health and safety rules and regulations.

### Danger resulting from improper use

Any work carried out by an unqualified person may result in damage to the installation or in physical injury.

- Do not perform any maintenance work on this appliance unless you are a qualified professional.

### Intended use and applicable areas of use

This appliance is intended for use as an appliance for domestic hot water production. The intended use of the appliance includes the following points:

- following the instructions for operating, installing, and maintaining this appliance and all other parts and components of the system.
- ensuring the compliance with all conditions of inspection and maintenance which are listed in this manual.

### Humidity and water splashes

The appliance should be installed in an area where it is not exposed to humidity and without any risk of being splashed by water.

### Rules and regulations (directives, laws, and standards)

Once the appliance is installed and switched on, all decrees, directives, technical rules, safety measures and standards, must be respected in their current version in effect.

- This appliance can be used by children of at least 3 years of age and by persons with reduced physical, sensory or mental capabilities or lacking experience or knowledge, if they are properly supervised or if they have been given instructions on how to use the appliance safely and if the risks involved have been understood.
- Children should be supervised to ensure that they do not play with the appliance.
- Cleaning and maintenance of the appliance should not be undertaken by children without proper supervision.
- Children aged 3 to 8 years are only allowed to turn on the tap connected to the domestic hot water heat pump.

A method of disconnection ensuring a complete cut-off according to Category III conditions must be installed in the fixed piping to conform to installation regulations.

Protect the appliance with:

- a 10A (D-curve) all-pole circuit breaker with a contact opening of at least 3mm.
- a protective 10A (D-curve) circuit breaker with a 30mA differential.

### **WARNING**

Do not use any means to speed up the defrosting process or to clean, other than those recommended by the manufacturer.

The appliance must be stored in a room which does not contain a perpetual flame or other source of ignition (for example: open flame, gas powered appliances or electric radiators in use).

Do not pierce or burn.

**Warning:** refrigerant fluids may be odourless.

The product is not intended to be operated at an altitude greater than 2000m.

- Water may drain from the discharge pipe of the pressure limiting device. This pipe should be kept open to open air.
- Verify that the ventilation openings are not obstructed.
- A **new** pressure-relief valve (not included) **must** be installed and set to 6 bars on the domestic cold water supply of the appliance. We recommend using a membrane valve.
- This valve must conform to all national standards in effect (NF EN 1487).
- The pressure-relief drainage outlet should be installed in a frost-free place and in a downward sloping position.

### **Maintenance - Troubleshooting**

- Drainage: Turn off the power supply and the cold water, open the hot water valves and then set the safety group to the drainage position.
- The pressure-relief valve should be activated regularly so as to eliminate limescale and check for blockages.
- If the electrical supply cable is damaged, it must be replaced by the manufacturer, their customer service technicians, or by a qualified professional to avoid risk of injury.
- See the § «Dimensions» pages and the § «Installation» pages of this manual to find the necessary dimensions for the proper installation of this appliance.
- See the § «Hydraulic connections» pages of this manual to find the minimum and maximum water pressures and temperatures.
- Repair and maintenance of electrical components must include initial safety checks and component inspection procedures.
- If there is a defect that could compromise safety, then no power supply should be connected to the product until it is satisfactorily processed. If the defect cannot be corrected immediately but must be allowed to work then an adequate interim solution must be used. This must be reported to the equipment owner so that all parties are informed.
- Initial security controls must include:
  - Discharge of capacitors: Discharge safely to avoid sparking.
  - Verification that no electrical components are energized and that no wiring is exposed during system charging, recovery or purging.
  - That there is continuity of connection to the ground.

### **Repair of intrinsically safe components**

Intrinsically safe components are the only components that can be used in the presence of a flammable atmosphere. The equipment used must be properly sized.

## 2 - RECOMMENDATIONS



The appliance can only function when filled with water. Never turn on the appliance if the tank has not been properly filled with water and completely purged of air.

### 2.1 - Storage



**STORAGE PRECAUTIONS:**  
Admissible storage and transport temperatures of the heat pump water heater are from -5°C to +35°C.

### 2.2 - Transport



The product can be tilted on a 90° face. This is indicated on the cardboard packaging. In case of horizontal transport, the product must be tilted gradually. It is forbidden to tilt the product on the other sides.

Forbidden

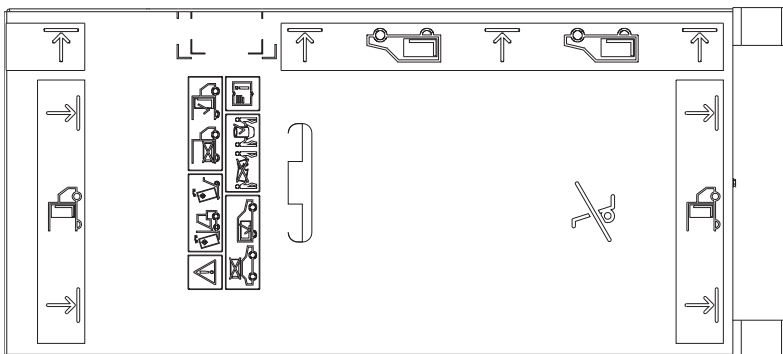

Accepted

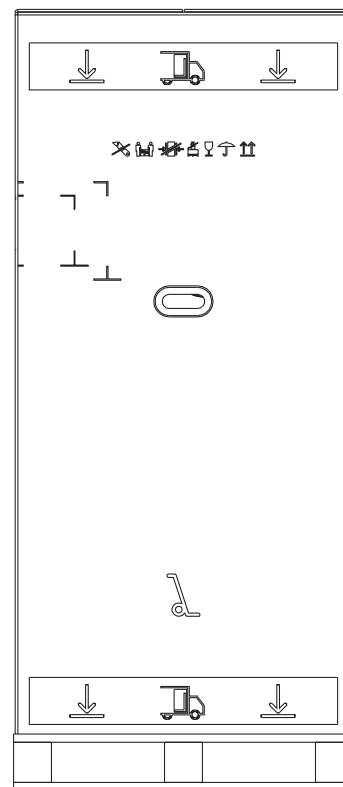
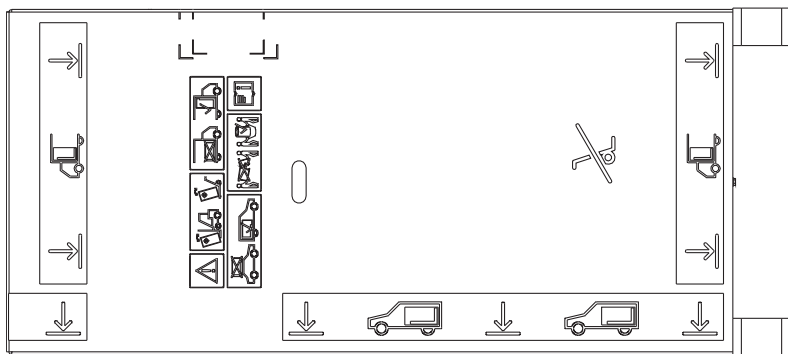

We do not guarantee the damage caused by a transport or handling of the product that is not in accordance with our recommendations.

## 2.3 - Handling

The appliance is supplied with a transport bag, to facilitate handling to the installation site.

### Admissible transportation positions :

All other transport positions are forbidden



### Non-admissible transportation positions :



The upper covers of the appliance are not made to withstand force and should not be used for handling purposes.



All other transport positions are FORBIDDEN.



If tipped, the centre of gravity will shift towards the top: handle with care.



Once the heat pump water heater is installed in its definitive place, it is imperative to wait at least 60 minutes before switching it on the first time.

## 2.4 - Contents of packaging

- 1 domestic hot water heat pump.
- 1 hydraulic derivation module.
- 1 documentation bag containing 1 installation manual, 1 guarantee card, a bag of two dielectric fittings and 3 adjustable feet.
- 1 transport bag.

## 2.5 - Unpacking

- Remove cardboard packaging.
- Remove the centring cardboard.
- Remove the bag of accessories and the transport bag.
- Without tilting the appliance, use the appropriate tool to remove the screw from beneath the wooden pallet.
- Use the transport bag to move the appliance to its final location.

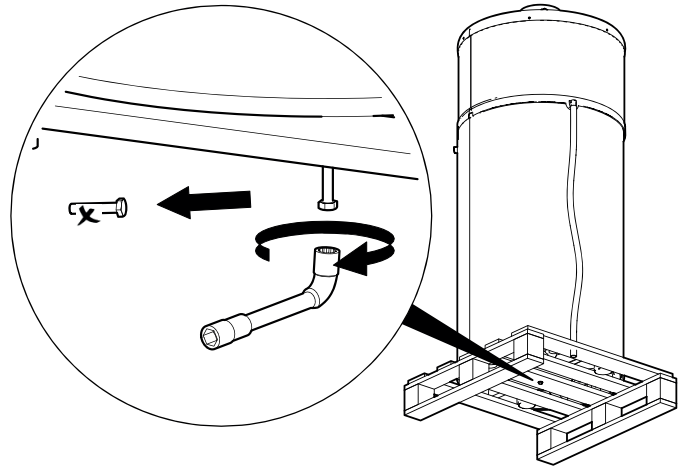

Keep the protective bag out of the reach of children (risk of suffocation).

- Remove the inner compressor holding block.

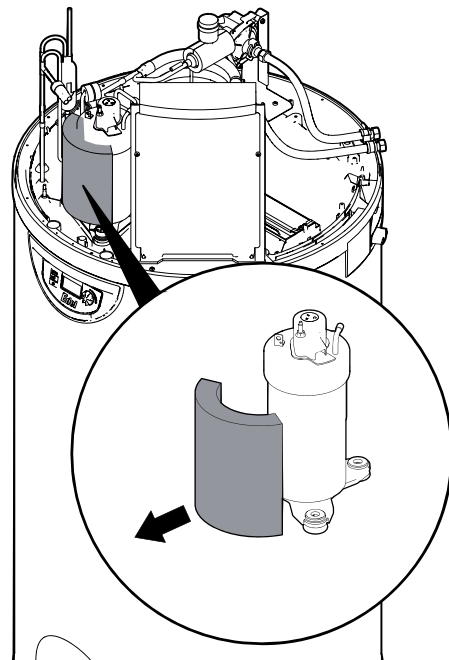

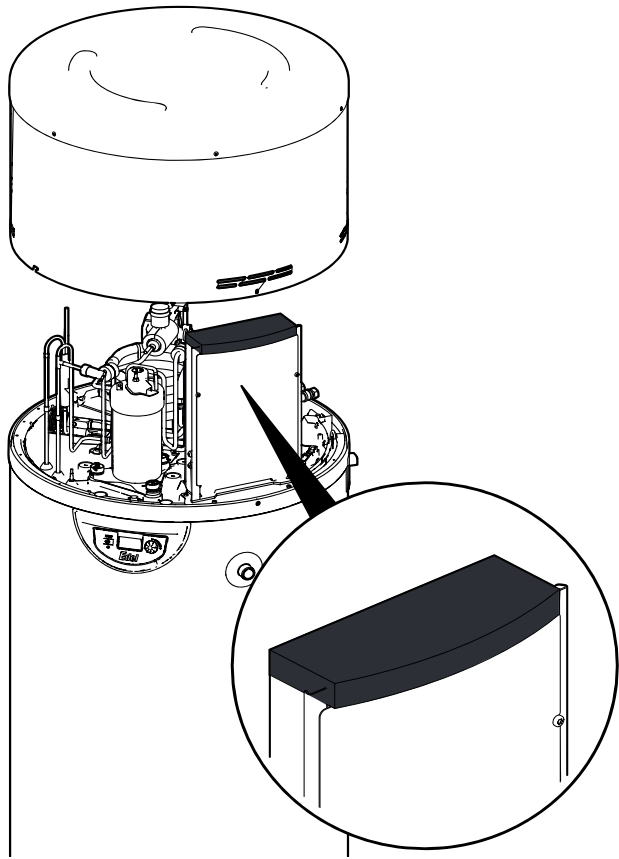

## 3 - OPERATING PRINCIPLE

The domestic hot water heat pump is a small-capacity heat pump dedicated to the production of domestic hot water. The appliance uses the floor's returns for the capture of calories and then the bonuses to the water of the tank. That is made possible by the use of refrigerant fluid allowing the transfer from one medium to another. This appliance has the particularity of operating on the R290 gas, guaranteeing good thermodynamic performance and negligible environmental impact.

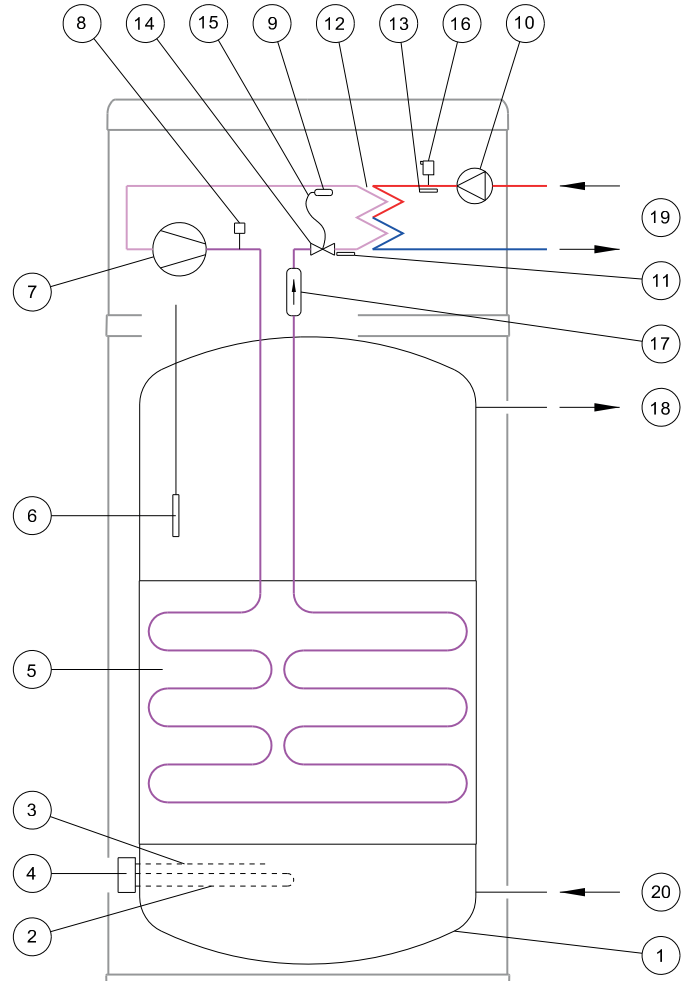

Rep.	Description	Rep.	Description
1	Tank	11	Evaporator sensor
2	Electrical resistance	12	Evaporator
3	Safety aquastat	13	Floor sensor
4	Safety aquastat	14	Expansion valve
5	Capacitor	15	Capillary expansion valve
6	Domestic hot water sensor	16	Manual purger
7	Compressor	17	Drying filter
8	Pressure switch	18	Domestic hot water outlet
9	Expansion valve bulb	19	Heated floor inlet/outlet
10	Circulator	20	Domestic cold water inlet



**When handling the cover, verify that the insulation on the top of the electrical box remains in position.**

### 2.6 - Symbols used



**Caution:** contains a flammable refrigerant fluid. Please respect all installation and handling precautions.



Consult the installation manual before carrying out any work on the appliance: handling, installation, use, or maintenance.



Contains regulated substances, do not dispose of in the garbage. In case of decommissioning, please follow all environmental regulations on the recuperation of all electrical and electronic equipment.

## 4 - INTRODUCTION

### 4.1 - Dimensions

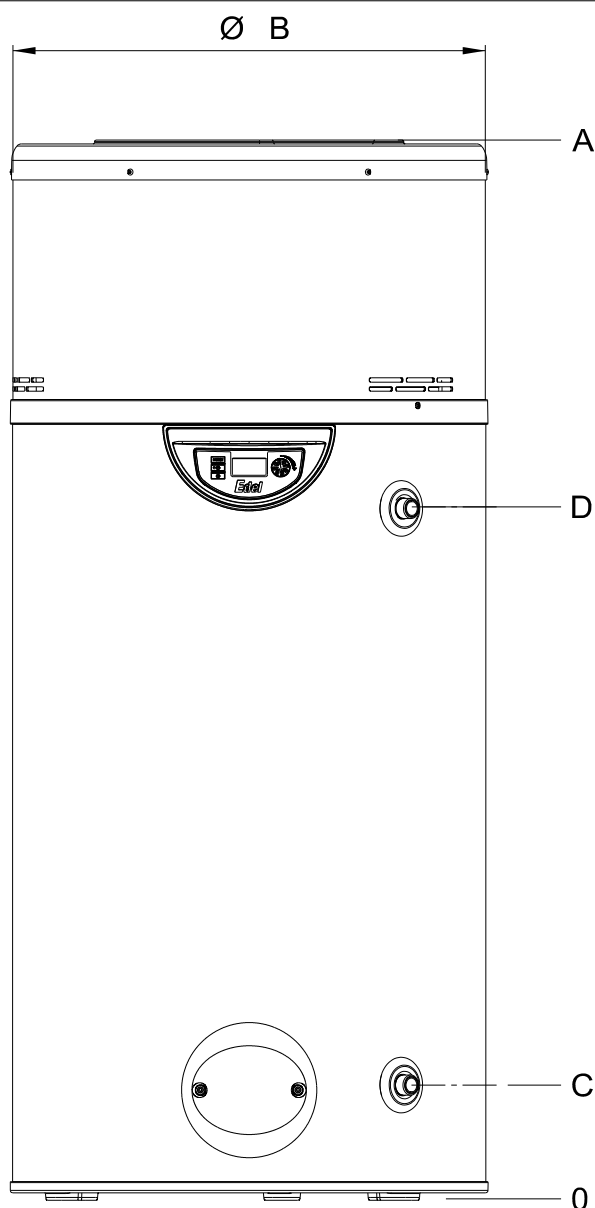

Rep.	Description	200L	270L
A	Overall height	1410mm	1730mm
B	Tank diameter	630mm	630mm
C	Height cold water inlet	153mm	153mm
D	Height hot water inlet	921mm	1243mm

### 4.2 - EU declaration

This device complies with international electrical safety standards IEC 60335-1, IEC 60335-2-21, IEC 60335-2-40. The CE marking present on the device attests to its conformity with the following Community Directives, of which it meets the essential requirements:

- Low Voltage Directive (LV): 2014/35/EU.
- Electromagnetic Compatibility Directive: (EMC): 2014/30/EU.
- Ecoconception Directive for Energy-related products: 2009/125/EC.
- Limiting Hazardous Substances (ROHS): 2011/65/EU.

### 4.3 - Technical specifications and performances

Water source heat pump water heater		200L	270 L
<b>Heat pump performance</b>			
Nominal volume	L	200	270
Max. input power	W	1600	1600
Water temperature range	°C	+18 to +50	+18 to +50
DHW* temperature with heat pump	°C	60	60
Max. heat pump power consumption	W	400	400
Water flow rate	L/h	250	250
Sound power level	dB(A)	44	44
Refrigerant	-/kg	R290 / 0,110	R290 / 0,110
Global warming potential	kg	0,330 kg CO <sub>2</sub> equivalent	0,330 kg CO <sub>2</sub> equivalent

<b>Normative Data (EN 16147)</b>			
Draw cycle	-	M	L
COP* (water +25°C)	-	4,17	4,26
Reserve capacity	W	17	24
Hot water reference temperature	°C	54,1	54,7
Heating time	-	7h24	10h29
Energy class	-	A+	A+
Seasonal energy efficiency	-	179	179
Vmax	L	253	343
V40 td	L	662	747

<b>Dimensions and connections</b>			
Dimensions	mm	Ø630xH1410	Ø630xH1730
Weight when empty	kg	46	54
Hydraulic connection diameters	-	F 3/8"	F 3/8"
Connection diameter for DCW* and DHW*	inches	M3/4"	M3/4"
Electrical power supply	V-Hz-A	230V-50Hz-10A	230V-50Hz-10A
Protection rating	-	IPX1	IPX1
D-curve circuit breaker	A	10	10

<b>Tank</b>			
Materials / protection	-	Stainless steel	Stainless steel
Maximum service pressure	MPa	0.6 (6 bars)	0.6 (6 bars)
Built-in electrical back-up power (87°C safety setting)	W	1200	1200
Max. temp with electrical back-up	°C	65	65

\*DHW= Domestic hot water  
COP= Coefficient of performance

DCW= Domestic cold water



# 5 - INSTALLATION

## 5.1 - Placement and positioning

### 5.1.1 - Placement choice



#### INSTALLATION PRECAUTIONS:

- The appliance must not be installed near a perpetual flame or other source of ignition.
- The appliance must be installed in such a way as to avoid mechanical damage.

#### • It is FORBIDDEN to install the appliance:

- outside.
  - in an enclosed and unventilated space of less than 2m<sup>3</sup>.
  - in rooms exposed to frost, or where the temperature is less than 5°C, including when the appliance is in operation.
  - in humid rooms with significant vapour emissions (eg. a bathroom).
  - to operate the appliance with air intake which contains solvents or flammable materials.
- Avoid placing near bedrooms to reduce noise pollution.

### 5.1.2 - Positioning and anchoring

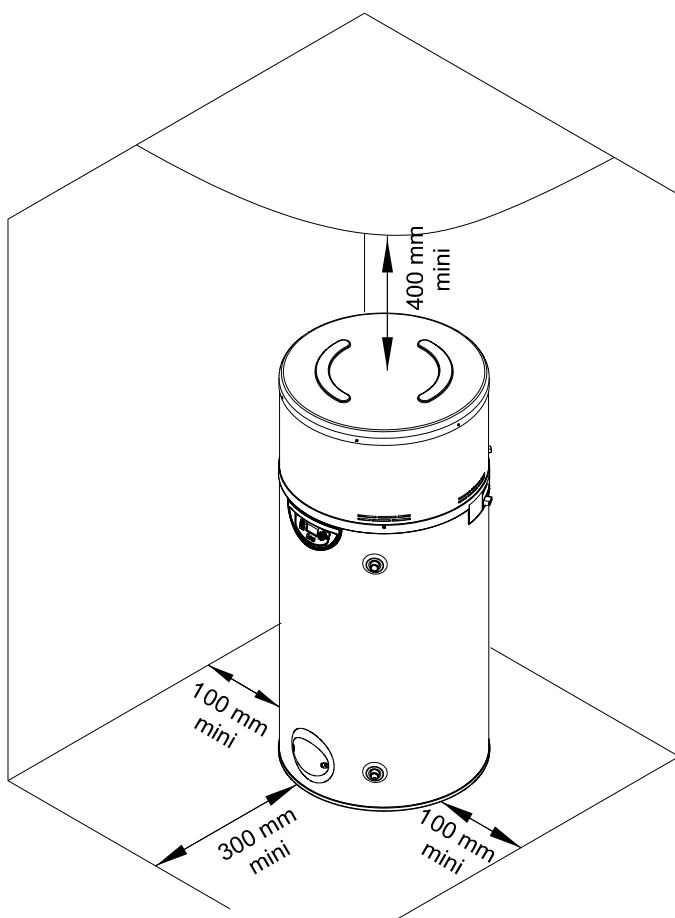

- To ensure normal operation of the Domestic hot water heat pump and to facilitate maintenance work, it is necessary to respect a minimum amount of free space around the appliance as well as a minimum ceiling height to allow for the removal of the cover.

Non-authorized mounting zones for thermodynamic water heaters 200 & 270 l:

#### Envelope volume:

The envelope volume is the volume that is outside the bathtub or shower cabin and is limited, on the one hand, by the vertical cylindrical surface circumscribed to the bathtub or shower cabin and, on the other hand, to the horizontal plane located at 2,25m from the bottom of the bath or shower basin.

#### Protection volume:

The protection volume is the same height as the envelope volume, but with an additional 1 metre of space added to its width (from the edge of the bathtub or shower cubicle) so that a person in the shower cubicle or bathtub may not reach out and touch the appliance or any electrical connections.

- The floor must be able to support the weight of the full water heater (weight of domestic hot water heat pump when filled with water 200 L / 270 L = 246 kg / 324 kg).



**La verticalité du chauffe-eau thermodynamique doit être respecté.**

For this purpose, use the three adjustable feet provided in the documentation bag of the installation manual (see below).

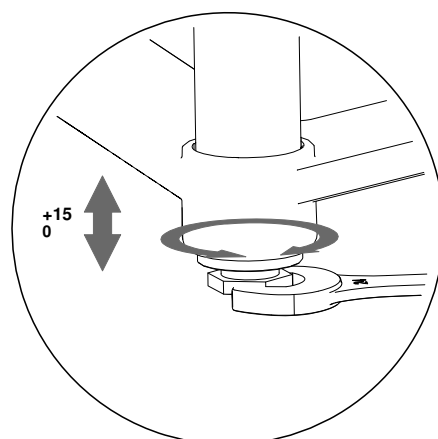
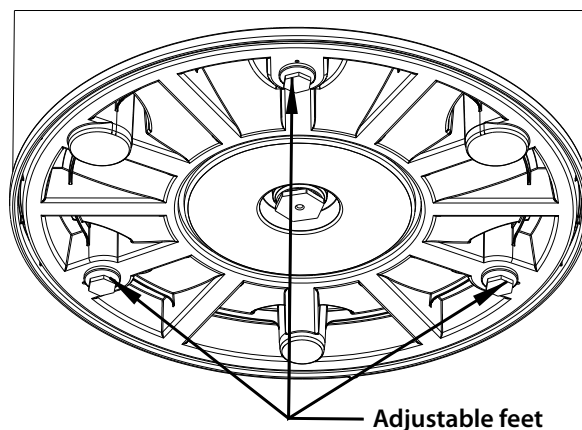

### 5.1.3 - Options

#### 5.1.3.1 - Primary circuit mixing valve

Primary circuit  
thermostatic mixing  
valve > 50°C  
ref: 730010

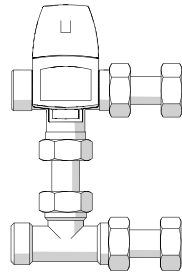

### 5.1.4 - Included accessory

#### 5.1.4.1 - Hydraulic derivation module

Hydraulic derivation  
module  
réf: B4591222

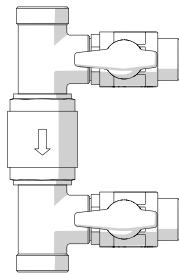

## 5.2 - Hydraulic connections to the underfloor heating circuit

The appliance is connected using the return flow of the underfloor heating network via a derivation module provided with the tank.

In winter, the **Edel** draws heat from the return of the heating circuit until its set temperature is reached. To limit the impact on the heating capacity available in the coldest outdoor conditions, the heating emitter should be oversized by 1 kW.

### 5.2.1 - Underfloor heating derivation module

#### 5.2.1.1 - Description

The floor derivation module is a hydraulic accessory which is delivered as standard with the heat pump, which allows the connection of the heat pump water heater to the water return flow from the underfloor heating circuit.

For water return over 50°C, installation of a primary circuit thermostatic mixing valve is necessary >50°C (**See § Options**).

### 5.2.1.2 - Underfloor heating derivation module circulator

Power consumption 10W; electrical current required 0.05A

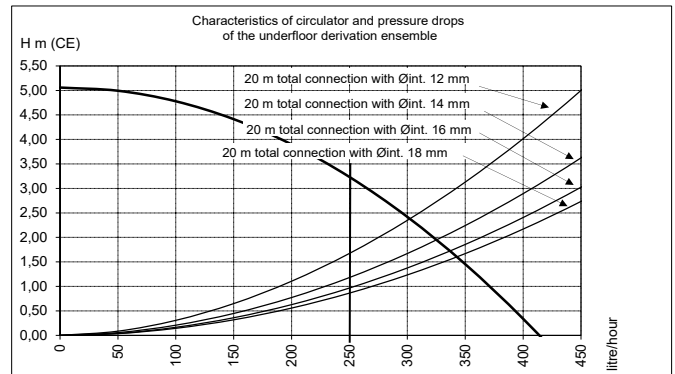

The length and diameter of the plumbing inlet/outlet connection between the floor derivation module and the heat pump water heater must be adapted to the circulator so that the flow drawn from the floor is more than 250 l/h.

Example above without thermostatic mixing valve: with 20m of connection with an interior diameter of 14 mm, the total pressure drop is 2.00m for a flowrate of 325 l/h.

### 5.2.2 - Filter

It is recommended to install a filter on the inlet piping of the water heater to protect the circulator and the plated heat exchanger.

### 5.2.3 - Radiators

The heat pump water heater is not compatible with a radiator circuit (the volume of water in the radiators is insufficient, and condensation will form on the surface of the radiators during the summer months).

### 5.2.4 - Minimum surface area for underfloor heating

To avoid operation of the heat pump using the electrical back-up instead of the heat pump, a minimum surface area for underfloor heating should be respected according to the capacity of the appliance:

Heat pump water heater	Minimum surface area of underfloor heating
200 L	90 m <sup>2</sup>
270 L	100 m <sup>2</sup>

### 5.2.5 - 3-way mixing valve for underfloor heating circuit

With the presence of a 3-way mixing valve (rep.16), it is **imperative** to place the derivation kit between the underfloor heating collector and the 3-way valve bypass as indicated on the diagram below:

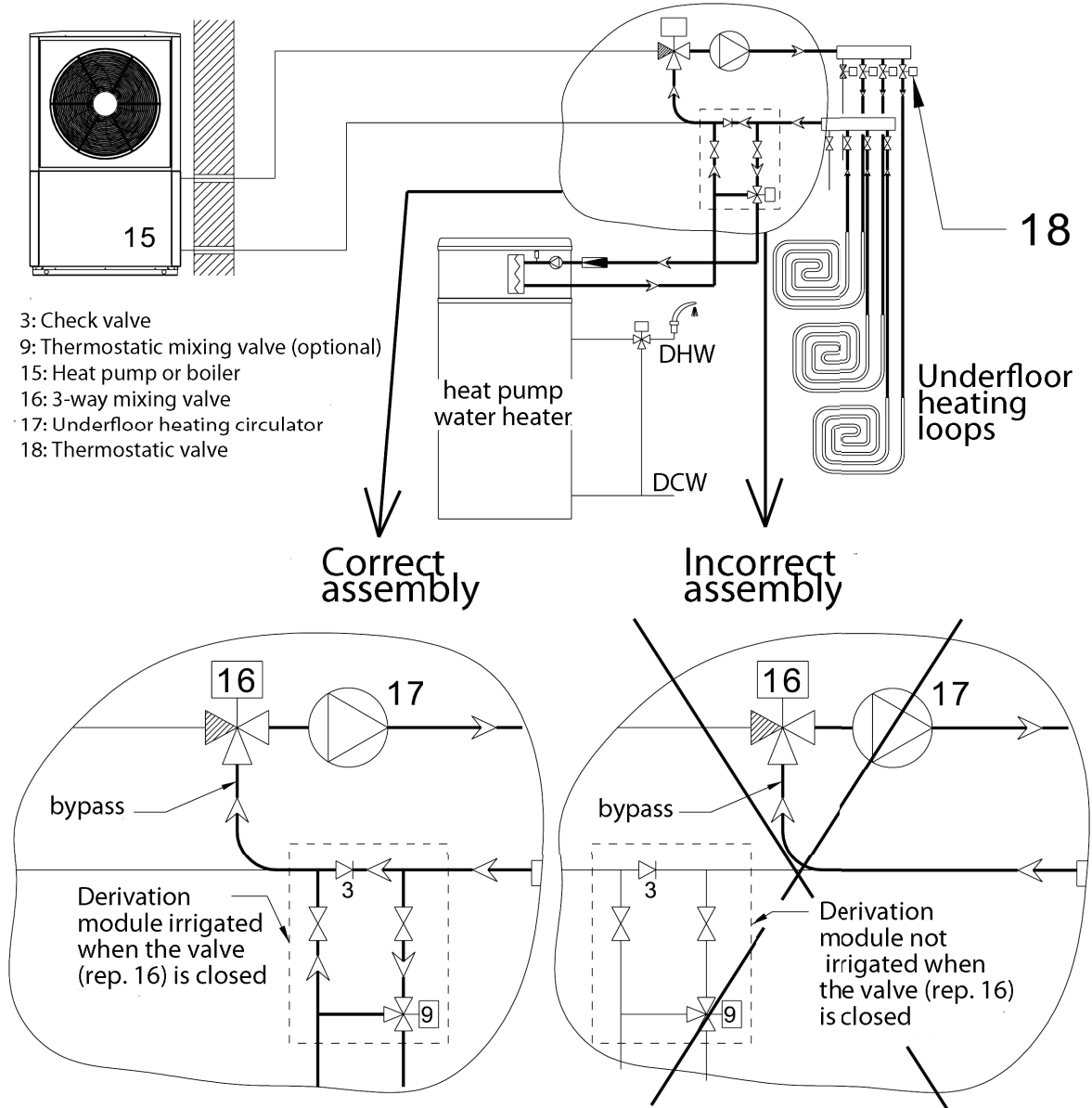

### 5.2.6 - Thermostatic mixing valves equipping the water loops of the underfloor heating circuit

If there are thermostatically controlled valves equipping the recirculating pumps for the underfloor heating circuit on the appliance, (rep.18), leave them permanently open (by manually opening them or by disassembling the thermostatic head).

The permanently irrigated flooring should have the minimum surface area necessary for the capacity of the appliance.

This is to avoid damaging the circulator equipping the heat pump water heater and limits the running of the electrical back-up instead of the heat pump.

### 5.2.7 - Underfloor heating circuit circulator

To help the circulator equipping the heat pump water heater if it is distanced from the derivation module (long distance or the diameter of connection is too weak), let the underfloor heating circuit circulator (rep.17) run permanently, summer and winter.

This allows to limit operation of the appliance using the electrical back-up instead of the heat pump.

### 5.2.8 - Treatment of the water in the heating circuit



**It is MANDATORY to read the additional document concerning the quality of water used for filling the installation. This document is included with this manual as well as in the packet with the warranty information.**

**This document also contains information which is PERTINENT to the WARRANTY of the material.**

If the domestic hot water heat pump is connected to an installation with existing underfloor heating, it is necessary to thoroughly rinse and treat the installation.

### 5.2.9 - Filling water

The materials used for the production of a heating circuit have differing properties. These properties can create a phenomena of corrosion through the creation of a galvanic bridge in new installations as well as in older ones.

The filling of the water circuit must be done only with water from the domestic water network using untreated water (no softener). Using water from any other source (well water, rain water, etc..) will render the warranty null and void.

### 5.2.10 - Treatment of the heating circuit



**Central heating systems MUST BE CLEANED to eliminate debris (copper, fibres, soldering fluxes) related to set-up and installation, as well as to avoid chemical reactions between the metals.**

**It is also important to TO PROTECT THE CENTRAL HEATING SYSTEM AGAINST RISKS OF: CORROSION, LIMESCALE, AND MICROBIAL DEVELOPMENT by using an APPROPRIATE corrosion inhibitor for all types of installations (steel or cast-iron radiators, underfloor heating). PRODUCTS USED FOR THE TREATMENT OF HEATING WATER USED MUST COMPLY WITH ALL NATIONAL STANDARDS IN THE COUNTRY OF INSTALLATION.**

We recommend the use of products in the SENTINEL range for preventative and curative treatment of the heating circuit.

#### • For new installations : (less than 6 months old):

- Clean the installation with a universal cleaner to eliminate the debris from the installation (copper, fibres, soldering fluxes) Example: SENTINEL X300 or SENTINEL X800.
- Thoroughly rinse the installation until the water runs clear, with no traces of impurities left.
- Protect the installation against corrosion with a corrosion inhibitor, example: SENTINEL X100. Or against corrosion and freezing with an inhibitor with an anti-freeze additive. Example: SENTINEL X500 or SENTINEL R600.

#### • For existing installations:

- Desludge the installation with a desludging product to eliminate any sludge from the installation. Example: SENTINEL X400 or SENTINEL X800.
- Thoroughly rinse the installation until the water runs clear, with no traces of impurities left.
- Protect the installation against corrosion with a corrosion inhibitor, example: SENTINEL X100. Or against corrosion and freezing with an inhibitor with an anti-freeze additive. Example: SENTINEL X500 or SENTINEL R600.

#### Corrosion inhibitor:

- protects against the formation of limescale
- prevents «pinhole» type corrosion
- prevents in new installations, the formation of sludge and the proliferation of bacteria (in low temperature networks: algae)
- prevents the formation of hydrogen
- eliminates the sound of the generators

Treatment products from other manufacturers can be used if they guarantee that the product is appropriate for all the materials used in the appliance and offers efficient resistance to corrosion. To find this information refer to their user manual.

### 5.2.11 - Purging the installation

The oxygen present in the air is extremely corrosive. Therefore, for a permanent purging of the installation to be effective, place automatic or manual air purgers at each high point of the installation, and manual purgers on each radiator.



#### **RENDERING THE WARRANTY NULL AND VOID**

**All deterioration of the appliance due to an inappropriate quality of water and/or the presence of corrosion in the absence of treatment products as described above, and/or an improper purging of air of the installation will render the warranty null and void.**

- Connect the floor derivation module to the return flow of the underfloor heating of the installation. Take care of the proper orientation of the check valve (see § «Underfloor heating derivation module» and «Description»).

### 5.3 - Connection to the domestic water supply

- A **new** pressure-relief valve (not included) **must be installed** and set to 6 bars on the domestic cold water supply of the appliance. The use of a membrane valve is recommended. This valve must conform to all local and national standards.
- The pressure-relief valve should be installed as close as possible to the appliance's cold water inlet and the water flow **should never be hampered by any accessory** (valve, pressure-reducer, etc.).
- The pressure-relief valve drainage outlet should be sized according to building regulations and standards and must never be obstructed. It should be connected to a vertically draining pipe, using a funnel which allows an open space of at least 20mm and which is at least equal in diameter to the appliance's piping connection.
- The pressure-relief valve drainage outlet must be installed in a frost-free place and in a downward-sloping position.
- If the pressure of the domestic cold water supply is higher than 5 bars, a pressure-reducer should be installed above the pressure-relief valve near the starting point of the installation (a pressure of 4-5 bars is recommended).
- It is advised to fit a shut-off valve above the pressure-relief valve.
- For installations equipped with:
  - piping of a small diameter
  - ceramic plate valves

A domestic water expansion vessel, or anti-hammer valves which are adapted to the installation should be installed as close as possible to the shut-off valve.

- **The following materials should be used for the domestic hot water circuit:**

- copper
- stainless steel
- brass
- plastic

**If the materials used in the domestic hot water circuit are incompatible, corrosion damage may occur.**

Domestic hot water pipes **with a cast-iron or steel link, or with dielectric fittings** (supplied) to avoid an iron/copper galvanic bridge.

- Thoroughly flush the supply line piping before connecting the appliance to the domestic installation so as not to introduce any particles, metallic or other, into the appliance.
- Respect the standards in effect in the country of use, notably domestic water regulations and pressure safety regulations.
- The maximum domestic hot water temperature at the distribution points should never surpass 50°C for toilets, and 60°C for other uses. Adequate thermostatic mixing valves should be installed to avoid risk of burns.
- The appliance must operate using water with a TH between 12°F and 30°F. In regions with extremely hard water (TH>25°F), it is recommended to treat water with a softener.
- Not following the conditions shown below, see DTU 60-1, will lead to the warranty of the tank to be rendered null and void (the values are given for a water at 20°C).

Resistivity	<2200Ωcm or >4500Ωcm	
Complete alkalimetric title	<1.6 meq/L	8°F
CO <sub>2</sub>	>15 mg/L	-
Calcium (Ca <sup>++</sup> )	<1.6 meq/L	8°F
Sulfates (SO <sub>4</sub> <sup>-</sup> )	>2 meq/L	10°F
Chlorides (Cl <sup>-</sup> )	>2 meq/L	10°F
Sulfates and Chlorides(SO <sub>4</sub> <sup>-</sup> +Cl <sup>-</sup> )	>3 meq/L	15°F



**The warranty does not apply if any of these points have been neglected or if the water quality did not allow correct treatment within the legal framework or if regular inspections of the anode are not carried out.**



**The use of a recirculation pump is strongly discouraged. This appliance is not designed for use with a recirculation pump. Use of a recirculation pump will cause a significant lowering of the temperature of the water in the tank.**

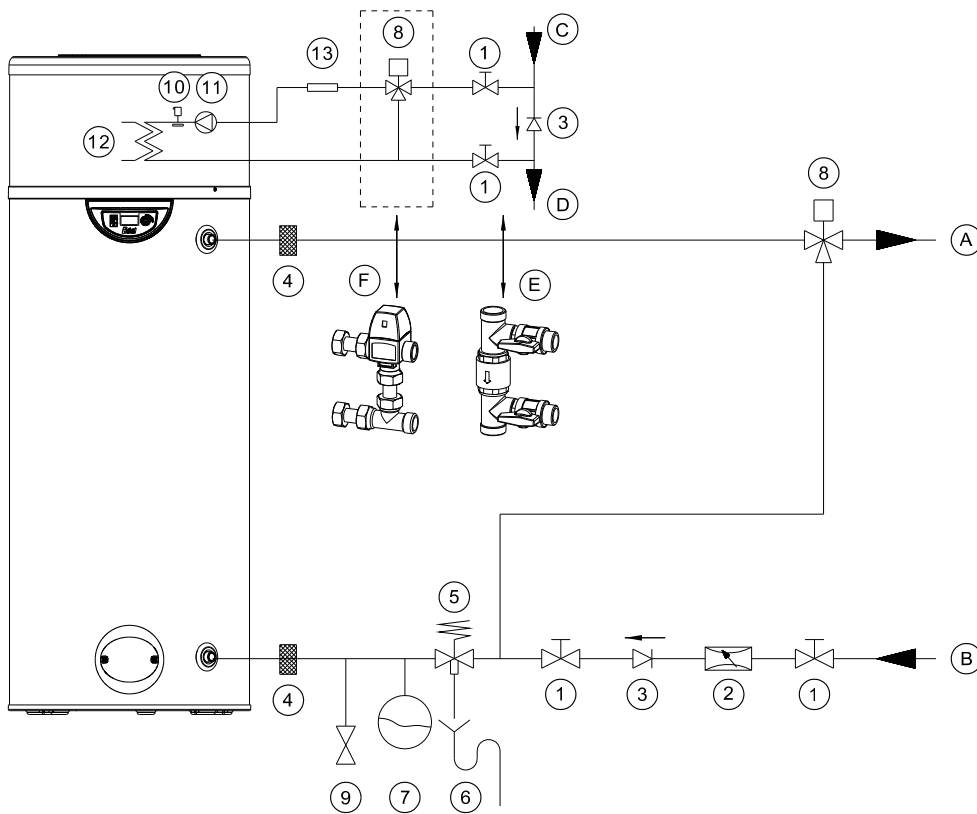

- A. Domestic hot water (DHW)
- B. Domestic cold water (DCW)
- C. Underfloor heating
- D. Vers retour générateur de chauffage
- E. Primary circuit mixing valve
- F. To the heating unit return

- 1. Stop valve
- 2. Pressure reducer
- 3. Check valve
- 4. Dielectric fittings (supplied)
- 5. Pressure-relief membrane valve (not supplied)
- 6. Run-off siphon
- 7. Domestic expansion vessel
- 8. Thermostatic mixing valve
- 9. Drainage valve
- 10. Manual purger
- 11. Water supply circulator
- 12. Plated heat exchanger (evaporator)
- 13. Filter (not supplied)

Domestic water connections must not be connected directly to the pipes. They must be fitted with a dielectric fittings (supplied with the appliance).

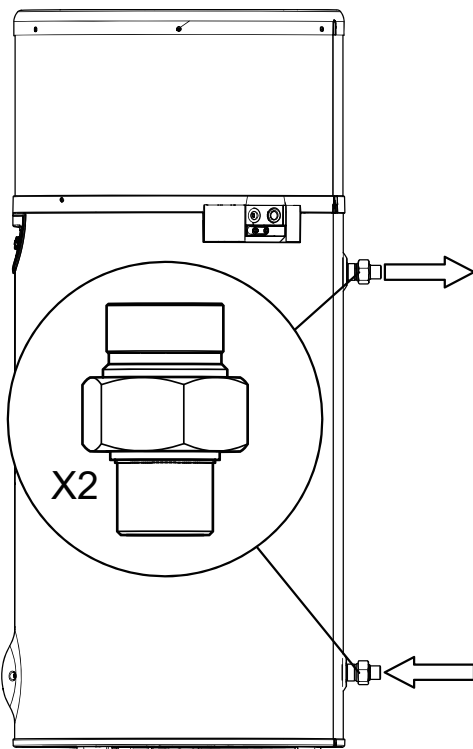

## 5.4 - Electrical connections

**Do not connect the heat pump water heater to the electrical line of a pre-existing water heater which used the peak / off-peak hours contact. The heat pump water heater must be permanently connected to the power supply, and the peak / off-peak control is done by either programming, or through the use of an independent cable. Grounding is mandatory.**

**Power supply = 230V single phase + ground.**

The power supply should comply with all regulations in effect in the country of installation, as well as the NFC 15-100 standard.

A method of disconnection which ensures a total power-cut in category III conditions should be installed in fixed piping in compliance with the installation rules.

- Protect the appliance with:
- an 10A (D-curve) all-pole circuit breaker with a minimum 3mm contact opening.
  - a protective 10A (D-curve) circuit breaker with a 30mA differential.

If the power supply cable is damaged it must be replaced by the manufacturer, their customer service technicians, or by a qualified technician to avoid any risk of injury or danger.

### 5.4.1 - Remove the top cover

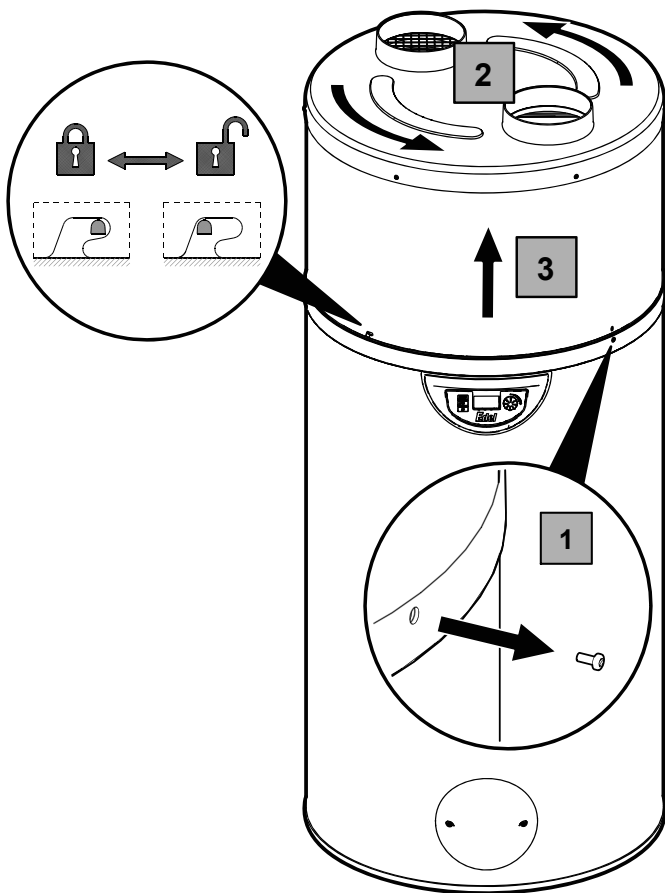

### 5.4.2 - External control



**Only an external connection using a voltage free «dry contact» is authorised, otherwise there is a risk of damaging the electronic circuit board.**



**It is discouraged to operate the Heat pump during peak hours so as to optimise its operation.**

It is not necessary to connect the electricity metre's timer switch to program the heat pump water heater for peak/off-peak time operation.

The appliance's control panel can be used to program time slots for the heat pump water heater or for the electrical back-up to run (see § «Programming» for daily programming options).

### 5.4.2.1 - Peak / Off-peak hours contact

It is also possible to connect the electricity provider dry contact to the heat pump water heater without using programming.

- Contact open = Load shedding
- Contact closed = Normal operation

The load shedding level can be selected and programmed for the appliance (see § «Load shedding»).

By default, the electrical back-up does not run during peak hours.

To access the electrical connections:

- Remove the cover and the shell.
- Remove the cover of the appliance by taking out the screws which fix the shell onto the lower part of the appliance.
- Remove the black protective cover from the electronics board.

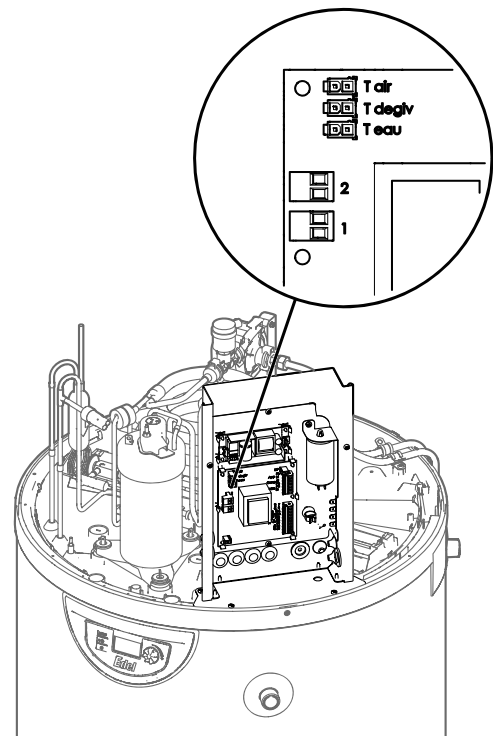

### 5.4.2.2 - Electricity provider contact

To prevent the electrical back-up from running during peak hours, connect the dry contact originating from the electricity counter, to terminal 1.

- Contact open = Back-up not allowed to run
- Contact closed = Back-up allowed to run

By choosing load shedding level 0 or 1 (see § «Load shedding»), you stop the electrical back-up alone from running (load shedding = 1) or the heat pump and the electrical back-up from running (load shedding = 0).

- Pass a 0.75mm<sup>2</sup> 2-wire cable with metal tips through a cable gland at the back of the appliance and bring the end of the cable around to the electronics board. The other end of the cable should be connected to the timer switch.
- Insert the 2-wire cable through a grommet from the electronics box.
- Connect the 2-wire cable to «Input 1» indicated on the electronics board, having removed the existing red bridge beforehand.

### 5.4.2.3 - Connection to the photovoltaic (PV) function

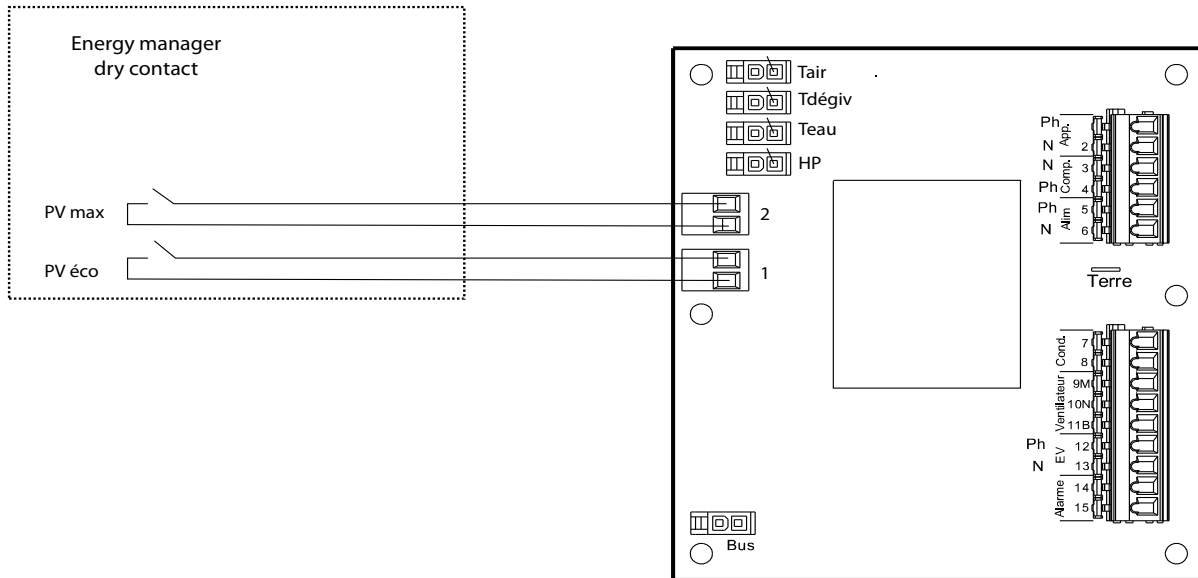

This function enables the appliance to operate in auto-production mode, which means that it will use the energy produced by the PV function to supply the heat pump as well as the electrical back-up, and to heat the water in the tank.

The connection is made between the energy manager electrical box (not supplied) and connectors 1 and 2 on the electronics board.

- Remove the protective casing.
- Remove the black cover from the electronics board.
- Connect the PV function cable to connector 1 on the electronics board.
- If the PV function regulator has two control contacts, connect them to connectors 1 and 2 on the electronics board. See § « Electrical box electrical diagram » in the appendix.
- Terminal 1: a low level of electrical energy is produced by the PV function.
- Terminal 2: a high level of electrical energy is produced by the PV function.



**CAUTION: Connectors 1 and 2 are for DRY CONTACTS ONLY. They must NEVER be connected to 230V.**



# 6 - SET-UP AND USE



**Deterioration risk: it is imperative to fill the tank with water before switching on the appliance or connecting it to the electrical supply.**

- Leave the appliance unplugged.
- Open the hot water valve located at the highest point of the installation.
- Open the cold water inlet located on the safety group.
- Fill the tank until water is coming out of the hot water valve located at the highest point of the installation.
- Close the hot water valve
- Before turning on the appliance, verify that the entire circuit is watertight.

The heat pump water heater operates **primarily with the heat pump** as long as the temperature of the water from the underfloor heating return flow is between 18°C and 50°C. Once the temperature is lower than 18°C or over 50°C, the water is no longer heated by the heat pump, but by the electrical back-up.

The temperature of the domestic hot water provided by the heat pump is adjustable to up to 60°C.

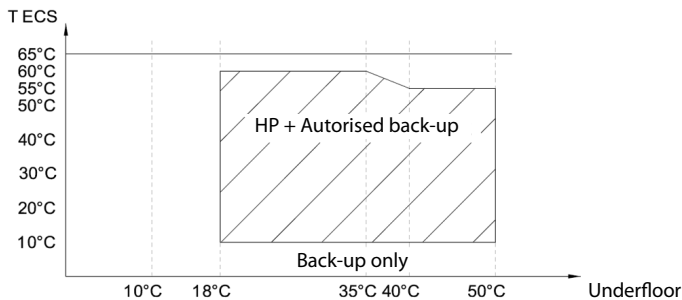

In the case of high domestic hot water consumption, the heat pump water heater has a comfort function,  $T^{\circ}C_{MIN}$  which increases the heating capacity when there is less than 1/3 of the tank's volume left at over 38°C (see § « $T^{\circ}C_{MIN}$  -minimum temperature-»). There is also a setting to activate the electrical back-up if the heating time is too long (see § « $MAX TIME$ »).

If more domestic hot water is required from time to time, the heat pump water heater has a «*BOOST*» function (activated by the user) which ensures that the water heats to the desired temperature (for example: 50°C) quickly with the help of the heat pump and electrical back-up. This function is deactivated as soon as the required temperature is reached (end of heating cycle).

From time to time, check that there are no alerts (in case of an alert, please refer to § «Error message codes»).

## 6.1 - Control panel

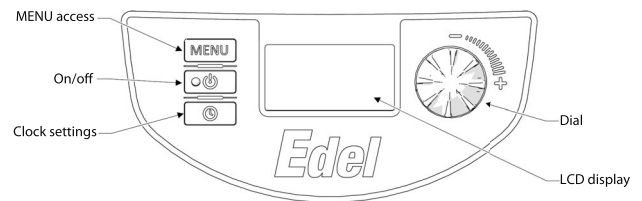

### Symbols and their designation:

- ..... Compressor operating
- ..... Electrical back-up operating
- ..... Domestic hot water requested
- ..... Comfort mode in progress
- ..... Eco mode in progress
- ..... Frost protection mode in progress
- ..... Holiday mode in progress
- ..... Keyboard locked
- ..... Regulation or display of a parameter in progress
- ..... Photovoltaic mode activated
- 123...7**.Date

## 6.2 - Setting the language

The language must be selected when the appliance is turned on for the first time. Turn the dial to the left and select «English». Confirm your choice by pressing on the dial. Access to the «*LANGUAGE*» menu is always possible.

- Press **MENU**.
- Turn the dial to scroll through menu options:

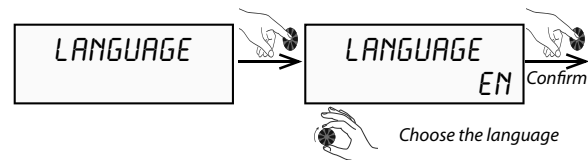

- Press **MENU** to return to the main menu.

## 6.3 - Setting the date and time

- Press «Clock settings» 

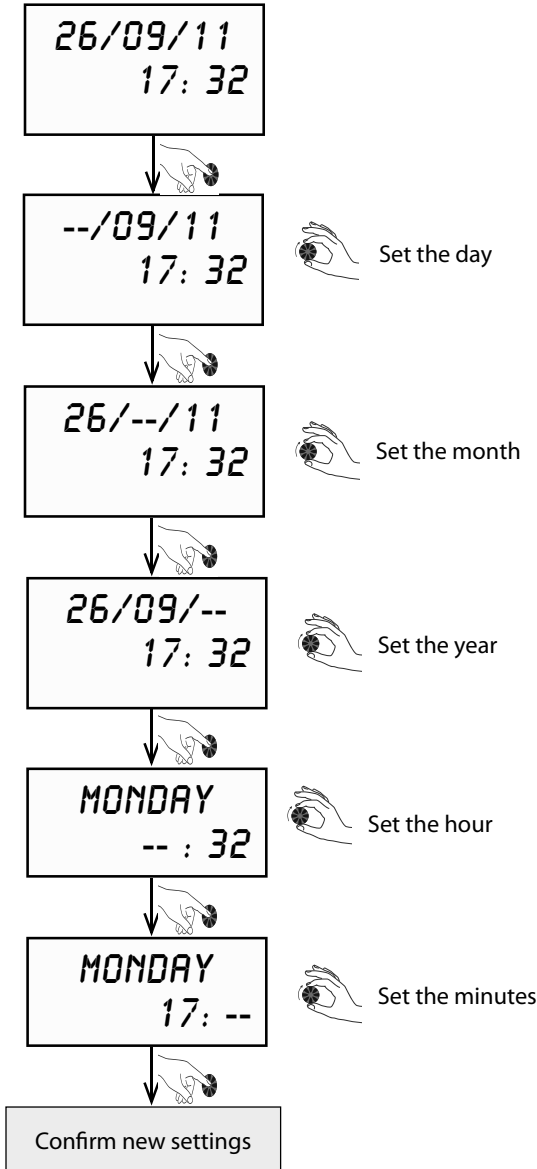

## 6.4 - Setting the desired water temperature

### 6.4.1 - PV mode deactivated

The water temperature can be adjusted from 30°C to 65°C. Up to 60°C, the water is heated using only the heat pump. From 60°C to 65°C, the electrical back-up takes over.

- Press **MENU**
- Turn the dial to scroll through the menu options:

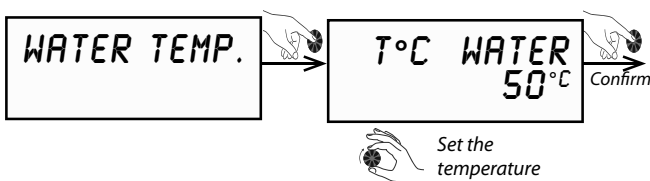

- Press **MENU** to return to the main menu.

### ACCU+ mode

If the domestic hot water setpoint is higher than that accepted by the heat pump, the product switches to «ACCU +» mode. The «ACCU +» function increases the amount of water in the product while maintaining minimum heat pump operating time.

- In order to get the best results from your heat pump, it is recommended that you do not set the water temperature too high unless necessary. The default temperature is set at 55°C.

**! If the water temperature is set at 50°C or below, we recommend programming an anti-Legionella cycle.**

### 6.4.2 - PV mode activated

When PV mode is activated, the water temperature can be set to a higher level to favour operation during periods of photovoltaic production.

- Press **MENU**
- Turn the dial to scroll through the menu options:

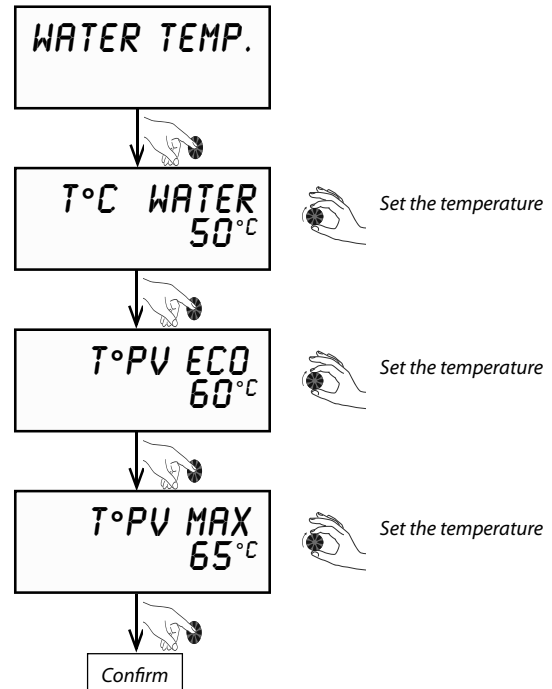

- Press **MENU** to return to the main menu.

The settings are available according to the following reasoning:

$$\text{TEMP} \leq \text{T}^\circ \text{PV ECO} \leq \text{T}^\circ \text{PV MAX} \leq 65^\circ \text{C}$$

**T°PV ECO 60°C** The heat pump heats the water in the domestic hot water tank to a higher temperature than the usual hot water temperature (mode «PV ECO»)

**T°PV MAX 65°C** The heat pump and the electrical back-up heat the water in the domestic hot water tank to a higher temperature than the PV ECO mode (mode «PV MAX»)

## 6.5 - Holiday/temporary standby mode

«*HOLIDAY*» mode puts the appliance on standby while the frost protection mode remains active. This function can be programmed to run between 1 and 99 days, and is in effect as soon as the number of days is confirmed.

• Press **MENU**

• Turn the dial to scroll through the menu options:

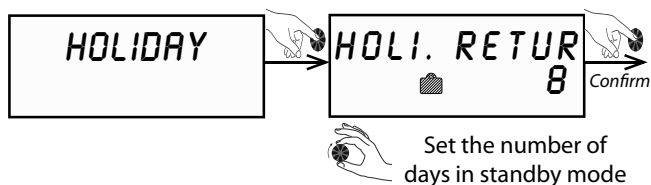

• Press **MENU** to return to the main menu.

«*HOLIDAY*» mode switches off automatically when the number of set days has ended. While in «*HOLIDAY*» mode the **heat pump water heater** displays «*HOLI. RETURN*» on the screen, as well as a countdown of the days remaining in standby mode.

## 6.6 - BOOST mode

(for occasional use and guaranteed comfort)

The «*BOOST*» function temporarily forces the electrical back-up and the heat pump to operate at the same time to speed up the heating time during a heating cycle. The «electrical back-up» symbol ⚡ flashes while it is activated.

• Press **MENU**

• Turn the dial to scroll through the menu options:



• Press **MENU** to return to the main menu.

The screen will blink for a few minutes and any actions on the keys will make it blink again.

The «*BOOST*» function is automatically deactivated as soon as the set temperature is reached (end of heating cycle).

## 6.7 - Electric mode (for operation using only the electrical back-up)

Electric mode «*ELEC MODE*» uses only the electrical back-up to heat the water in the heat pump water heater. It provides a back-up option if for any reason the heat pump is not running (piping not connected, dusty renovation work being carried out near the appliance...)

• Press **MENU**

• Turn the dial to scroll through the menu options:

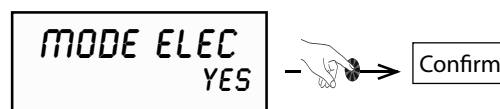

• Press **MENU** to return to the main menu.

The screen will blink for a few minutes and any actions on the keys will make it blink again.

## 6.8 - Programming

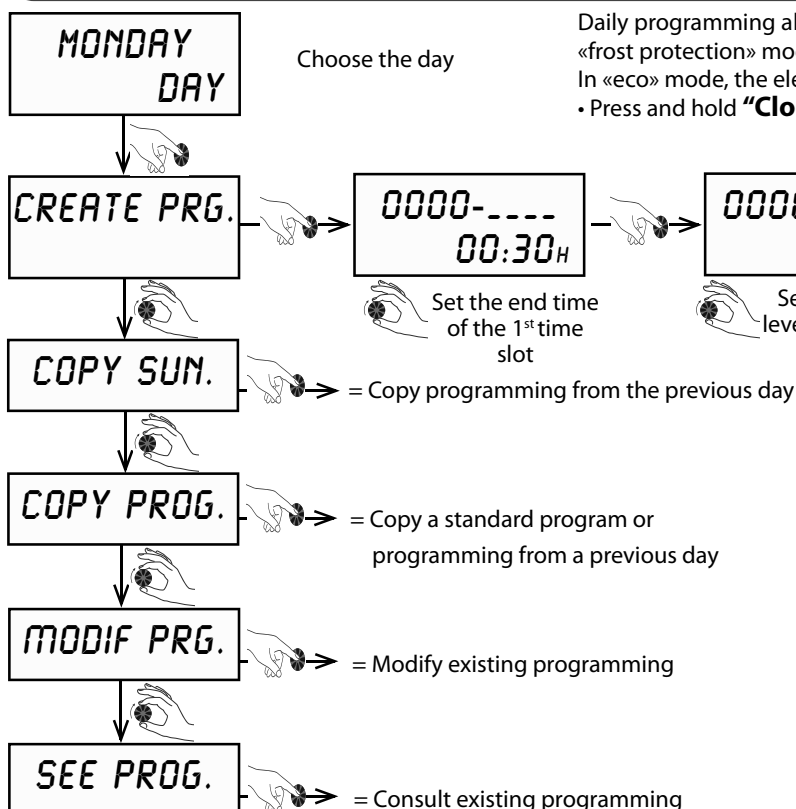

Daily programming allows to define the periods of operation in «comfort», «eco», or «frost protection» modes.

In «eco» mode, the electrical back-up is not authorised.

• Press and hold «**Clock settings**»  for 3 seconds.

...and so on, up to 7 time slots per day.



**Heating time for the tank varies according to outdoor temperatures. Ensure that the operating time of the appliance is not too limited.**

### Legend

**FROST PT** = Frost protection mode  
**ECO** = Heat pump alone running  
**COMF** = Heat pump alone running  
 + electrical back-up when needed

• Press **MENU** to return to the main menu.

## 6.9 - INSTALLER menu

It may be necessary to adjust certain temperature settings to optimise the performance of the **heat pump water heater**, depending on how the appliance is installed.

### Accessing the installer menu:

- Press **MENU**
- Turn the dial until «**INSTALLER MENU**» is displayed.
- Press the «**Clock settings**» and «**Menu**» buttons **at the same time**.
- **Keep both buttons pressed down** for 3 sec. until the screen displays «**PV MODE**».



To activate the photovoltaic function



To set installation parameters



To reset parameters to default settings



To display the temperatures of the different sensors and inlets



To consult the counters in operation

### 6.9.1 - PV mode

Parameter	Description	Unit	Time range	Factory setting
MODE PV	Activation of photovoltaic mode	-	yes no	no
PRIORITY	Interval of anti-legionellosis cycles	-	yes no	yes

- If the **PV mode** regulator is connected to terminals 1 and 2 on the electronics board, **PV mode** must be activated.
  - The electrical energy which is produced is stored in the form of hot water. The PV function can be set to two different levels of production.
  - **PV ECO** = the lower level of photovoltaic energy production. The heat pump generates a higher water temperature. The hot water temperature must be somewhere between the regular hot water temperature and 55°C (factory setting = 55°C).
  - **PV MAX** = the higher level of photovoltaic energy production. The heat pump and electrical back-up generate a higher water temperature. The hot water temperature must be somewhere between the **PV ECO mode** hot water temperature and 65°C (factory setting = 65°C).
- Turn the dial to select the mode :  
- **Menu** → **INST. MENU** → **PV mode**
- Select « **yes** »
- Press on the dial to confirm your selection.
- Press **Menu**.
- Set the desired domestic hot water temperature.
- Turn the dial to define the priority:  
- **Menu** → **INST. MENU** → **PV MODE** → **PRIORITY**

- **Yes**: the signals from terminals 1 and 2 have priority over frost protection and **eco mode**.
- **No**: frost protection and eco mode have priority over the signals from terminals 1 and 2.

**Note:** If the priority is given to **PV mode**, the domestic hot water is heated outside of defined hours (for example in holiday mode and outside of programmed time slots). If domestic hot water must only be heated during authorised time slots, set the priority to **no**.

- Press on the dial to confirm your choice.

### 6.9.2 - PERF mode



Allows to find the conditions of the performance test.  
Factory settings: No.



**Performance mode does not improve the product's performance, but returns it to the settings used during normative testing. Do not activate this function!**

### 6.9.3 - Setting the operating parameters

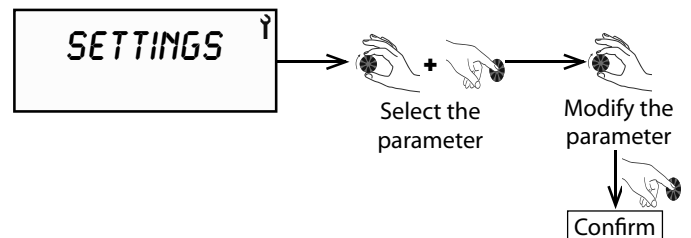

Parameter	Description	Unit	Time range	Factory setting
ANTI-BACT	Time interval for anti-legionellosis cycle	days	0-99	0
FAN MODE	Fan mode	-	1,2, or 3	1
T°C MINI	Min. temp for electrical back-up	-	0 or 1	0
SHEDDING	Load shedding level	-	0,1,2	1
MAX. TIME	Max. heating time	hours	No, auto, 1 to 24	No
TEMP MIN	Underfloor low temperature	-	Yes or No	No

- Press **MENU** to return to the main menu.

### 6.9.3.1 - ANTI-BACT Anti-legionellosis cycle

Factory setting - ANTI BACT = NO  
 Factory setting - WATER TEMP. = 60 C

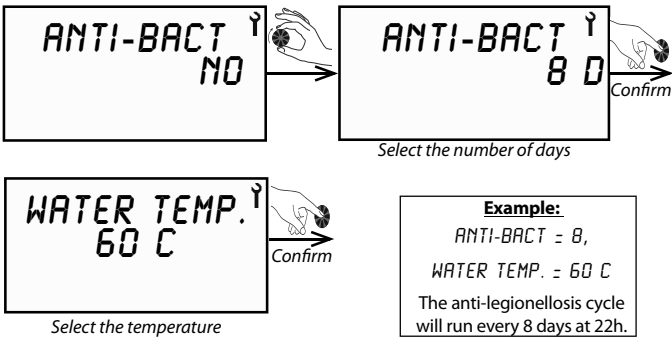

- Press **MENU** to return to the main menu.
- If the set temperature for domestic hot water is already 60°C (see § «Setting the desired water temperature»), there will be no anti-legionellosis cycle as it is already running continuously.
- If a cycle is interrupted by a period where the back-up is not allowed to run (electricity provider signal or programmed time slots) it will relaunch during the next authorised period.
- No anti-legionellosis cycle except when returning from holidays and after a frost protection period of more than 3 days.
- During the anti-legionellosis cycle the temperature is raised between 55°C and 70°C by the heat pump.

### 6.9.3.2 - T°C. MINI Minimum temperature

The electrical back-up can be activated at the same time as the heat pump to prevent the water temperature from falling below a minimum comfort level of 38°C. The electrical back-up will start up and raise the water temperature to 43°C, and then it will switch off and the heat pump will complete the heating cycle.

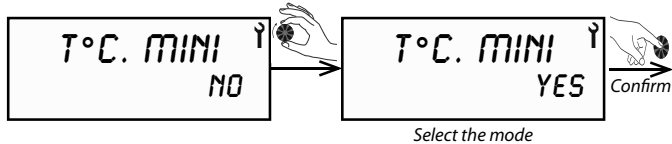

- This function is deactivated by default.
- In case of load shedding, the «T°C MINI» function is deactivated.
- Press **MENU** to return to the main menu.

### 6.9.3.3 - LOAD SHEDDING Level of operation authorised during peak time

When load shedding is activated you can choose to prevent certain elements from running (Electrical back-up and compressor).

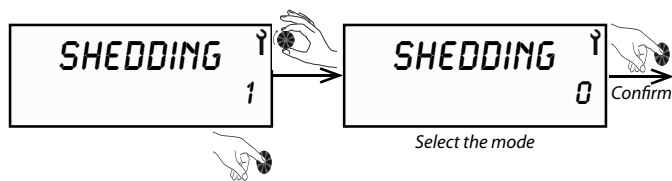

- If load shedding is switched on:
- MODE 0 = No element is allowed to operate
  - MODE 1 = Only the heat pump is allowed to operate
  - MODE 2 = The heat pump and back-up are allowed to operate (neutralising the «peak hours» function)

If PV mode is activated, load shedding from the (HP/HC) dry contact is not available. In this case it is necessary to use the programming of time slots (see § «Programming»).

- Press **MENU** to return to the main menu.

### 6.9.3.4 - MAX TIME Max heating time

It is possible to select the length of the desired heating time. The heat pump water heater can automatically use the electrical back-up at the same time as the heat pump to speed up the heating time of the tank.

If you choose MAX TIME = AUTO, the heating time is limited to a maximum of 5h during off-peak hours.

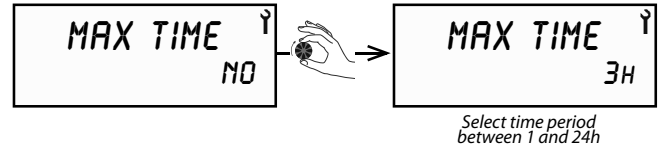

- This function is deactivated by default.
- Press **MENU** to return to the main menu.

### 6.9.3.5 - TEMP MIN Low temperature

The low temperature function allows the heat pump to be used when the floor temperature is above 10°C (compared with 18°C initially) and the domestic hot water temperature is above 30°C. Outside this range, heating is still provided by the electrical back-up.

Factory setting : TEMP MIN = No

Low temperature function: No

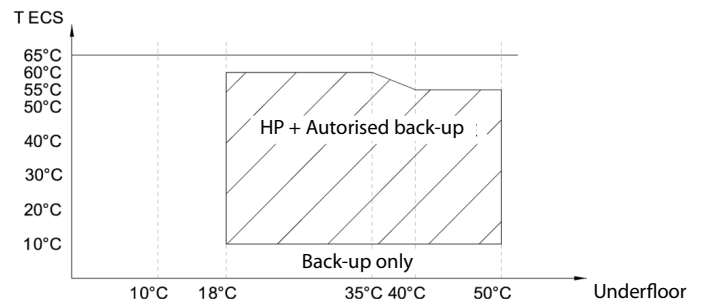

Low temperature function: Yes

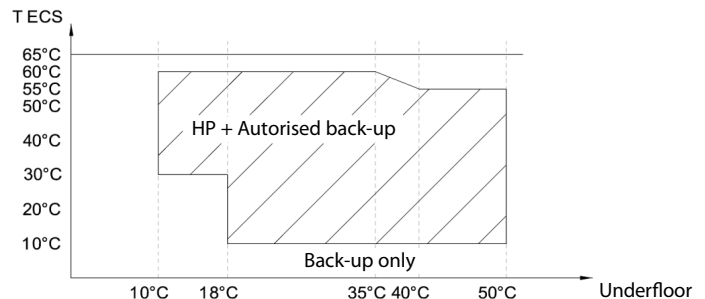

**If the low temperature function is activated, even greater care must be taken with the quality of the installation and maintenance of the appliance, as there is a risk of the coaxial exchanger freezing (refer to the additional document concerning the quality of the filling water).**

Activating the low temperature function may cause condensate to form on the evaporator. When this function is activated, the condensate tee + condensate drain hose assembly (**Ref. B1759620** - Not supplied) must be connected.

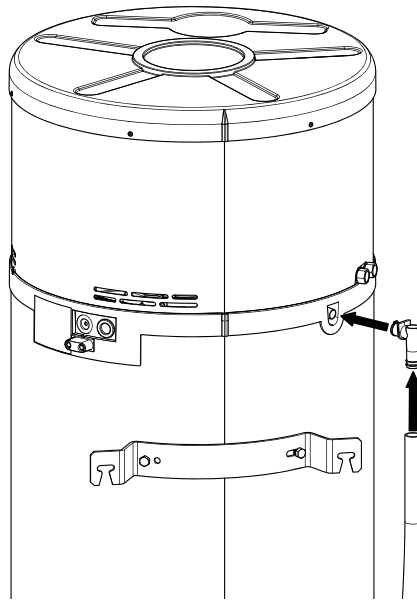

The drain pipe must lead to a wastewater trap.

To ensure correct drainage, the following points must be observed:

- The drain must lead through a siphon (the pipe must not be used as a siphon) into the waste water ;
- Fill the siphon with water;
- The drain pipe must be immersed in the water in the siphon;
- A minimum 3° slope must be maintained;
- It is forbidden to bend the hose;
- Do not connect to a nipple.



**The siphon is essential, as if it is connected directly to the waste water, rising sewage can damage the product's refrigeration circuit!**

## 6.9.4 - Locking the keyboard

### Automatic and permanent locking

The «**LOCKING**» menu enables you to create three possible levels of locking for accessing the menus.

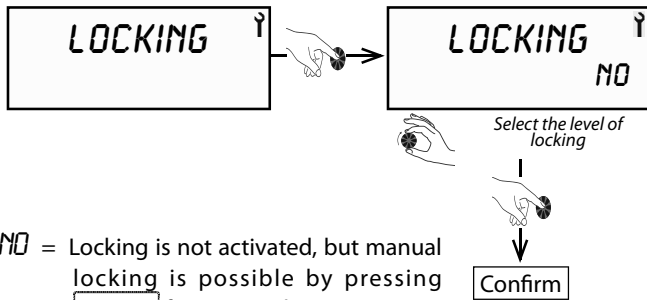

In the «**Installer**» menu turn the dial to «**LOCKING**».

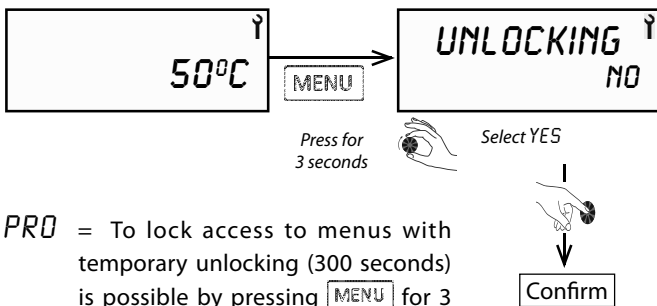

**NO** = Locking is not activated, but manual locking is possible by pressing **MENU** for 3 seconds.

**AUTO** = To lock menu access with temporary unlocking (60 seconds) press **MENU** for 3 seconds.



**PRO** = To lock access to menus with temporary unlocking (300 seconds) is possible by pressing **MENU** for 3 seconds and then  and  for 3 seconds.

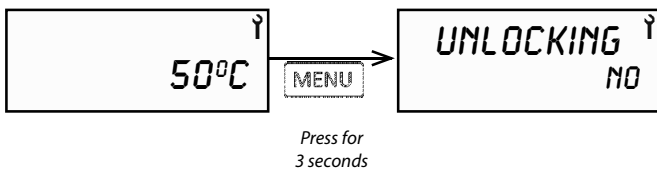

• When locking is activated, it is only possible to access unlocking and to reset the alarm.

### Manual locking from the main screen

It is possible to manually lock the keyboard from the main screen without gaining access through the «**Installer menu**» provided that locking settings are not already in place.

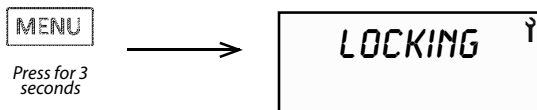

To lock manually, press **MENU** for 3 seconds.

## 6.9.5 - Resetting the parameters

Resetting the parameters allows you to return to the default settings.

Go to the «**Installer menu**», and turn the dial to «**RESET PARA.**».

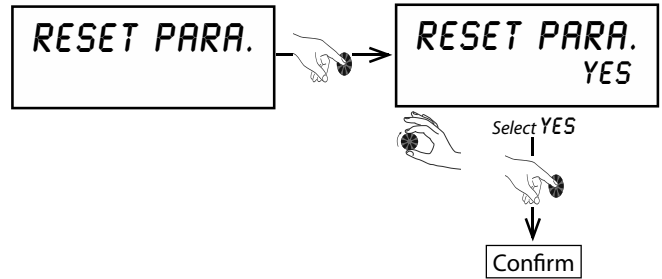

## 6.9.6 - Reading data

The «**READ DATA**» menu shows you, in real time, the information given by the sensors.

In the «**Installer**» menu, turn the dial to «**DISPLAY**».

Display	Description	Reference on electronics board
<b>WATER</b>	Domestic hot water temperature in lower part of tank	Teau
<b>FLOOR</b>	Temperature of water returned from the underfloor heating circuit	Tair
<b>EVAP</b>	Temperature of heat pump evaporator (expansion valve outlet)	Tdegiv
<b>If PV MODE (deactivated) factory settings, read data as follows:</b>		
<b>SHEDDING</b>	Off-peak hours switch (0-on; 1- off)	heures creuses
<b>HYGROSTAT</b>	Moisture sensor input (0-on; 1- off)	hygrostat
<b>If PV MODE (activated) read data as follows:</b>		
<b>PV ECO</b>	Contact input 1 (0-open; 1- closed)	1 heures creuses
<b>PV MAX</b>	Contact input 2 (0-open; 1- closed)	2 hygrostat

The temperature which is permanently displayed on the screen is the set temperature and does not necessarily indicate the temperature of the water immediately available in the tank.

## 6.9.7 - Counters

The «**Counters**» menu shows the number of start-ups from the heat pump and the electrical back-up.

In the «**Installer**», menu turn the dial to «**COUNTERS**».



- **COUNTER N°1:**  
Number of start-ups from the heat pump
- **COUNTER N°2:**  
Number of start ups from the electrical back-up
- **COUNTER N°4:**  
Accumulated heat pump running time

## 7 - MAINTENANCE AND TROUBLESHOOTING

In order to maintain efficiency and improve durability it is advised that an annual maintenance check be carried out by a qualified professional.



- Any work on the domestic hot water heat pump must be carried out by a qualified professional.
- Observe all health and safety rules!
- Any work on the refrigerant circuit must be carried out by a qualified professional with a Category 1 certificate of aptitude.
- The release of refrigerant fluid into the atmosphere is forbidden.
- The refrigerant must be collected before any work is carried out on the circuit.
- Switch off the domestic hot water heat pump before opening it.
- Wait for the fan to come to a complete stop before carrying out any work.
- Do not get water on any of the electrical parts.
- The pressure limiting device must be operated regularly to eliminate limescale and to check for blockages.

In case of maintenance or if taking the **domestic hot water heat pump** out of service, please respect the environmental protection regulations regarding recovery, recycling and disposal of consumables and components.



The R290 refrigerant in the heat pump circuit poses no risk to the environment, but it is flammable.

- The R290 refrigerant is odourless,
- do not damage the pipes in the refrigerant circuit,
- do not handle a flame or any other flammable source on the inside of the appliance.
- If the refrigerant is leaking, unplug the appliance, air out the room, and contact customer service.
- Do not use any mechanical means to speed up defrosting.
- Do not pierce or burn the appliance: in case of intervention on the refrigerant circuit, the refrigerant must be recovered.
- The refrigerant circuit containing flammable refrigerant fluid complies with national gas regulations.

.../...



.../...

→ In case of intervention on the refrigerant circuit:

- 1) Secure the area you will be working in.
- 2) Inform people of the potential danger involved in the work being carried out.
- 3) Check that the risk of inflammation is minimised.
- 4) Avoid working in a confined space; the area must be sufficiently ventilated.
- 5) Check the area with an appropriate leak detector before and during the work.
- 6) Place a CO<sub>2</sub> or dry powder extinguisher near the work area.
- 7) Do not smoke.



### 7.1 - Water circuit



It is **MANDATORY** to read the additional document concerning the quality of water used for filling the installation. This document is included with this manual as well as in the packet with the warranty information.

This document also contains information which is **PERTINENT** to the **WARRANTY** of the material.

The pressure-relief valve should be activated regularly so as to eliminate limescale and check for blockages.

Inspect the **domestic hot water heat pump's** hydraulic connections to ensure that they are all watertight.

### 7.2 - Water circuit for return flow from underfloor heating

The control of the water circuits is limited to the inspection of the filters and stopping up of any eventual leaks. Clean or replace clogged filters.

### 7.3 - Electrical maintenance

It is mandatory to periodically inspect for cleanliness and the absence of dust deposits on the electrical power board and the electrical connection terminals:

- of the compressor;
- of the electrical resistance;

Also check the lug connections to ensure proper tightness. The frequency of inspection must be adapted according to the air quality: a dusty environment requires more frequent inspection, at minimum once per year.

- Check that the wiring is not subject to wear, corrosion, excessive pressure, vibration, contact with sharp edges or any other adverse effects due to its environment.
- Maintenance must also take into account the effects of long-term continuous vibration from components such as compressor and fan





**Neglecting to clean the electronic circuit board and the electrical components could create a source of ignition.**

## 7.4 - Drainage

When draining the tank, ensure that there is a sufficient air intake at a high point of the tank so as to avoid any depressions in the tank.

Materials and products to avoid:

- brushes with steel bristles and steel wool pads
- scouring powder
- all bleach based or chloride products

- 1) Switch off the power supply.
- 2) Shut off the cold water inlet valve on the safety group and ensure there is an air intake valve on a high point of the appliance.
- 3) Open the hot water valves.
- 4) Set the safety group to the drainage position.

## 7.5 - Modification

Any modification of the appliance is prohibited. Any replacement of components must be done by a professional with original parts from the manufacturer.

## 7.6 - Decommissioning

### 7.6.1 - Leak detection

In the event of a prolonged absence with the power supply to the housing and the product disconnected, ask a qualified professional to drain the product or protect it from freezing.

Under no circumstances should potential ignition sources be used for the detection or detection of refrigerant leaks. A halogen flare (or other detector using an open flame) shall not be used.

- Electronic leak detectors may be used to detect refrigerant leaks, but for flammable refrigerants, sensitivity may not be adequate or may require recalibration.
- Ensure that the detector is not a potential ignition source and is suitable for the refrigerant used. Leak detection equipment must be set to a percentage of the lower flammability limit of the refrigerant and must be calibrated for the refrigerant used. The value of 25% of the lower flammable limit is used as the maximum.
- Liquid leak detectors are also suitable for use with most refrigerants but the use of chlorine-containing detergents should be avoided as chlorine can react with the refrigerant and corrode copper from the piping.
- If a leak is suspected, all open flames must be suppressed / extinguished.

### 7.6.2 - Removal and evacuation

- When opening the refrigeration circuit to perform repairs - or for any other purpose - conventional procedures must be used.
- For flammable refrigerants, it is important to use best practice as flammability must be considered.

• The following procedure must be followed :

- Remove the refrigerant ;
- Purge the circuit with inert gas ;
- Evacuate to the atmosphere;
- Purge with inert gas ;
- Open the circuit by cutting or brazing.
- Refrigerant must be recovered in a suitable recovery bottle.
- The system must be purged with nitrogen without oxygen.
- This process may need to be repeated several times. Compressed air or oxygen should not be used to purge refrigerant systems.
- The purge of refrigerants must be performed by breaking the vacuum in the system with nitrogen without oxygen: By filling up until the working pressure is reached, an evacuation to the atmosphere, and finally by vacuum pulling.
- This process must be repeated until there is no more refrigerant in the circuit.
- When the last oxygen-free nitrogen charge is used, the circuit must be brought to atmospheric pressure to allow intervention.
- Ensure that the vacuum pump outlet is not near potential ignition sources and that ventilation is available.

### 7.6.3 - Charging process

- Ensure that contamination of different refrigerants does not occur when using charging equipment. Hoses or lines should be as short as possible to minimize the amount of refrigerant they contain.
- Cylinders must be held in an appropriate position according to instructions.
- Make sure the refrigeration system is grounded before charging the system with refrigerant.
- Label the system when the load is complete (if not already done).
- Extreme precautions must be taken to not overload the refrigeration system.
- Before recharging the system, it must be pressure tested with the appropriate purge gas.
- The system must undergo a leak test at the end of the load but before commissioning. Another follow-up leak test must be performed before leaving the site.

### 7.6.4 - Decommissioning

- Before performing this procedure, it is essential that the technician knows the product and all its specificities.
- It is recommended to use best practices to ensure that all refrigerants are safely recovered. Before the task is performed, an oil and refrigerant sample must be taken in case an analysis is required before recycling the recovered refrigerant. It is essential that a power supply is available before the intervention begins.
  - a) Familiarize yourself with the product and how it works
  - b) Electrically isolate the system.
  - c) Before attempting the procedure, ensure that:
    - mechanical handling equipment is diponible, if necessary, for the handling of refrigerant cylinders ;
    - all personal protective equipment is available and used correctly ;
    - the recovery process is being overridden at all times by a competent person.
    - recovery equipment and cylinders comply with appropriate standards.

- d) Perform a «pump down» on the appliance where possible.
- e) If it is not possible to vacuum, make a manifold so that the refrigerant can be removed from various parts of the system.
- f) Make sure the recovery bottle is on the scale before the start of fluid recovery.
- g) Start the recovery group and operate it according to the instructions.
- h) Do not overfill bottles (no more than 80% in volume of liquid charge).
- i) Do not exceed the maximum operating pressure of the cylinder, even temporarily.
- j) Once the cylinders have been filled correctly and the process completed, ensure that the cylinders and product are removed from the site quickly and that all isolation valves on the product(s) are closed.
- k) Refrigerant must not be loaded into another refrigeration system unless cleaned and verified.

### 7.6.5 - Recovery

When transferring refrigerant into the recovery bottles, ensure that only the appropriate bottles are used. Make sure you have enough bottles to recover the entire system load. All cylinders used are dedicated to the refrigerant recovered and labeled for it (i.e., special cylinders for refrigerant recovery). Cylinders must be complete with pressure relief valve, associated shut-off valves and in good working condition. Empty recovery cylinders are evacuated and, if possible, cooled prior to recovery.

- Recovery equipment must be in good working order with all instructions at hand and must be suitable for recovery of all refrigerants including, where applicable, flammable refrigerants. In addition, a set of calibrated scales must be available and in good working order.
- Hoses must be complete with leak-free disconnects and in good condition. Before using the recovery machine, verify that it is in good working order, has been properly maintained and that all associated electrical components are sealed to prevent ignition in the event of a refrigerant leak. Consult the manufacturer if in doubt.
- The recovered refrigerant must be returned to the supplier in the appropriate recovery bottle and the transfer note filled in correctly. Do not mix refrigerants in recovery units and especially not in recovery bottles.
- If compressors or compressor oils need to be replaced, make sure they have been vacuum pulled to an acceptable level to ensure they are not left in the flammable refrigerant lubricant. Vacuum pulling must be done before the compressor is returned to the supplier. Only electric heating of the compressor body should be used to accelerate this process. When oil is drained from a system, it must be done safely.

### 7.6.6 - Recycling and Disposal

- The product must be labelled indicating that it has been taken out of service and emptied of the refrigerant.
- The label must be dated and signed.
- Ensure that there are labels on the product indicating that it contains a flammable refrigerant.

Entrust the disposal of the packaging to the installer who installed the product.



The above symbol requires:

- Do not dispose of the product with the household waste.
- Dispose of the product at a collection point for used electrical and electronic equipment.

## 7.7 - Troubleshooting

### • Not hot water

Check that:

- The volume of water consumed is not higher than the volume in the tank.
- The time period that the appliance operates is not too short (12h minimum if connected to piping).
- The water temperature is not set too low.
- There is no recirculating loop installed.
- The presence and proper positioning of water intake rods. The absence or incorrect placement of a rod may reduce the supply capacity of the hot water tank.

### • The Heat pump is not working

Check that:

- The set temperature is higher than the temperature of the water in the tank.
- There is a power supply to the appliance.
- The green LED light is on.
- The appliance is not in Holiday mode (🏠 symbol).
- The temperature of the return flow from underfloor heating is higher than 18°C.
- The timer has not been programmed to stop the appliance from operating («Frost protection» symbol on ❄️).
- There is not an error displayed on the screen (see § Error message codes).
- The appliance is not using the timer switch.
- That the water circulator is operating properly (clean if necessary).
- The underfloor heating derivation circuit is properly purged of air.

### • Water is too hot

Check that:

- The water sensor is properly placed in the well.

### • The electrical back-up's temperature limiting safety aquastat is engaged

Before resetting check that:

- The immersion heater is not covered in limescale deposits
- Clean or replace if necessary

### • The electrical back-up is not working

Check that:

- Your electricity provider or your timer is not preventing the appliance from functioning («Frost protection» symbol on ❄️).
- A heat-limiting safety thermostat for electrical back-up has not been activated after over-heating (>87°C). If this is the case, reset it.

Before resetting, check:

- That the heating element does not have limescale.
- Clean or replace if necessary.

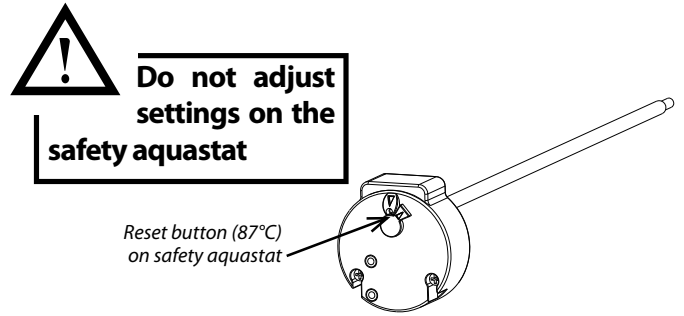

## 7.8 - NTC sensor data

All 4 **Heat pump water heater** sensors have the same ohmic values.

Temp. (°C)	Résist. R (KOhms)	Temp. (°C)	Résist. R (KOhms)	Temp. (°C)	Résist. R (KOhms)	Temp. (°C)	Résist. R (KOhms)
-10	56,200	10	20,700	30	8,045	60	2,343
-5	46,890	15	16,350	35	6,514	70	1,637
0	33,020	20	12,920	40	5,306	80	1,165
5	26,200	25	10,000	50	3,422		

## 7.9 - List of spare parts

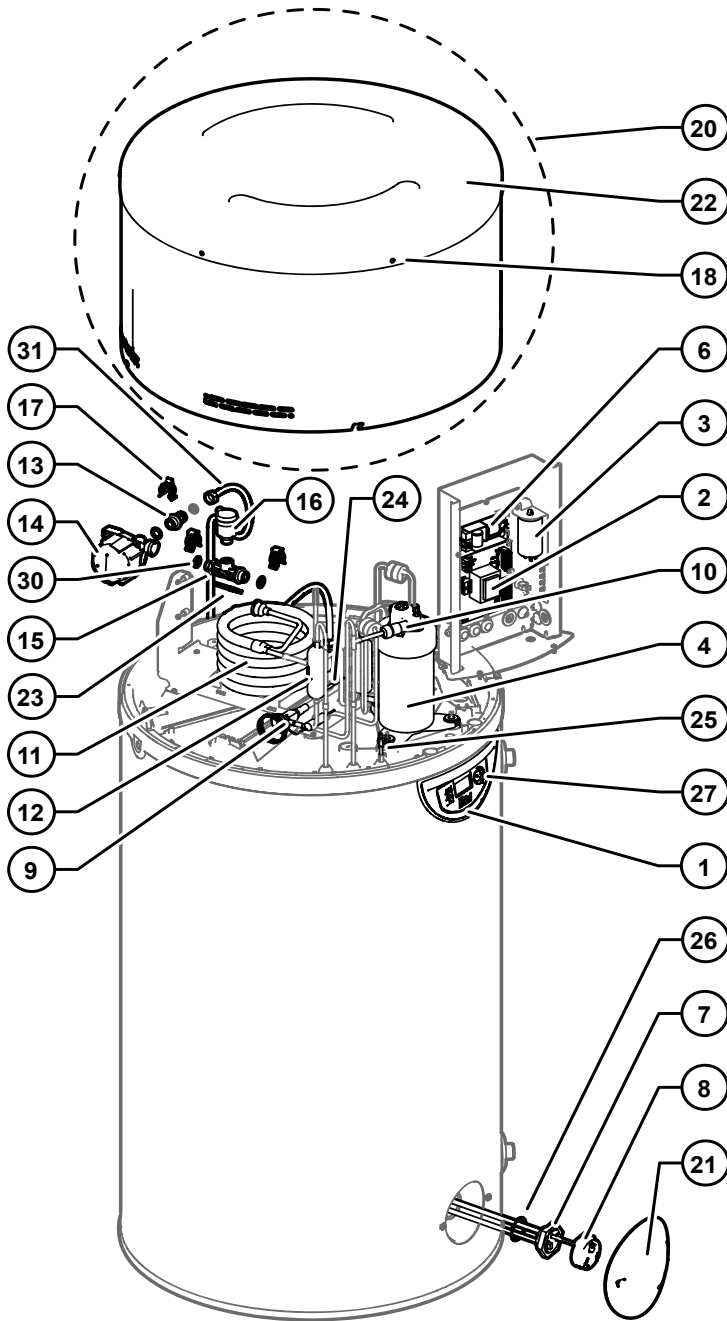

Rep.	200/270L	Description
<b>Regulation / display</b>		
1	B4993549	Control panel display
2	B1242042	C3S electronic circuit board controller
23	B1244833	Temperature sensor - lg 900mm
24	B1244522	Temperature sensor - lg 900mm
25	B1244575	Temperature sensor - lg 1200mm
<b>Electrical</b>		
3	B1244043	12 $\mu$ F capacitor
non visible	B1244251	Supply cable
non visible	B1242041	Domestic hot water heater WATER/3 wiring
6	B1244190	230Vac/24Vdc Transformer
<b>Refrigerant circuit</b>		
4	B4994150	Compressor kit
9	B1473097	Thermostatic pressure reducing valve
10	B1244424	Pressure swtich
11	B1473074	Plated heat exchanger
12	B1472871	Dehumidifying filter
non visible	B1973127	Refrigerant loading pipe
<b>Electrical back-up</b>		
7	B4992886	1200W heating element + seal
8	B1239160	Aquastat
26	B1657722	Heating element seal
<b>Plumbing</b>		
13	B1759168	Plastic connector G3/8"
14	B1244189	Circulator
15	B1759167	Purger connection
16	B4938819	Purger
17	B1454289	Clip
30	B1657763	Toric joint (O-ring)
31	B1447527	Braided flexible hose
non visible	B1594108	Dielectric fittings
<b>Casing</b>		
18	B0419930	Star rivets
20	B4595299	Upper cover kit
21	B1759551	Heating element cover
22	B1759144	Upper cover
27	B1758866	Control panel dial
non visible	B1759346	Adjustable foot

### **Nota** : availability of spare parts :

The spare parts of our products are kept available for 10 years, from the date of stop of mass production, except events beyond our control.

## 7.10 - Error message codes: errors, solutions and operating in case of error

**Note:** Errors can be dismissed by briefly pressing the dial (manual reset)

Display	Error	Probable causes	Temporary operating measures while waiting for the problem to be resolved	Solutions
MEMO/BUS	<ul style="list-style-type: none"> <li>Electronic board defect</li> <li>Bus wire defect</li> <li>Display screen defect</li> </ul>	<ul style="list-style-type: none"> <li>Voltage too high on electrical network</li> <li>Wiring error during electrical connection (connection to electricity provider or moisture sensor.)</li> <li>Damage during transportation</li> </ul>	<ul style="list-style-type: none"> <li>Heat pump non-functional</li> </ul>	<ul style="list-style-type: none"> <li>Replace main electronics board or</li> <li>Replace display screen board</li> </ul>
T_AIR	<ul style="list-style-type: none"> <li>Underfloor heating water sensor defect (temperature of water inlet from the underfloor heating circuit)</li> </ul>	<ul style="list-style-type: none"> <li>Sensor not functioning</li> <li>Sensor unplugged from board</li> <li>Sensor cable damaged</li> </ul>	<ul style="list-style-type: none"> <li>Heat pump non-functional</li> <li>Electrical back-up heats water to 43°C (38°C minimum)</li> </ul>	<ul style="list-style-type: none"> <li>Replace sensor</li> </ul>
T_DEFROST	<ul style="list-style-type: none"> <li>Evaporator sensor defect (de-frosting temperature)</li> </ul>	<ul style="list-style-type: none"> <li>Sensor not functioning</li> <li>Sensor unplugged from board</li> <li>Sensor cable damaged</li> </ul>	<ul style="list-style-type: none"> <li>Heat pump non-functional</li> <li>Electrical back-up heats water to 43°C (38°C minimum)</li> </ul>	<ul style="list-style-type: none"> <li>Replace sensor</li> </ul>
T_WATER	<ul style="list-style-type: none"> <li>Tank water sensor defect</li> </ul>	<ul style="list-style-type: none"> <li>Sensor not functioning</li> <li>Sensor unplugged from board</li> <li>Sensor cable damaged</li> </ul>	<ul style="list-style-type: none"> <li>Heat pump non-functional</li> </ul>	<ul style="list-style-type: none"> <li>Replace sensor</li> </ul>
CLOCK	<ul style="list-style-type: none"> <li>Clock/timer defect</li> </ul>	<ul style="list-style-type: none"> <li>Voltage too high on electrical network</li> <li>Damage during transportation</li> </ul>	<ul style="list-style-type: none"> <li>Programmed heating periods are no longer valid: the water is maintained continuously at the standard set temperature (if no signal or control is connected to the «external control» switch)</li> </ul>	<ul style="list-style-type: none"> <li>1-Press «clock settings» and set date and time</li> <li>2-If the error message does not disappear, replace the electronics board</li> </ul>
OVER PRESS	<ul style="list-style-type: none"> <li>Heat pump pressure too high</li> </ul>	<ul style="list-style-type: none"> <li>No water in the tank</li> <li>Water is too hot (&gt;75°C)</li> <li>Water sensor removed from tank</li> <li>Defective water sensor</li> </ul>	<ul style="list-style-type: none"> <li>Heat pump is non-functional</li> <li>Automatic reset</li> </ul>	<ul style="list-style-type: none"> <li>Check that the tank has been properly filled with water and purged of air</li> <li>Change the water sensor</li> <li>Check that the water sensor is in the right position in the tank</li> </ul>
LOW PRES.	<ul style="list-style-type: none"> <li>Heat pump pressure too low</li> </ul>	<ul style="list-style-type: none"> <li>No water flow</li> <li>Circulator pump blocked or not functioning</li> <li>Circulator not properly purged</li> </ul>	<ul style="list-style-type: none"> <li>Heat pump non-functional</li> <li>Electrical back-up heats the water to 43°C (38°C minimum)</li> </ul>	<ul style="list-style-type: none"> <li>Check that the circulator pump is working</li> <li>Check if the circulator pump is clogged, and unplug if necessary</li> </ul>
OVERHEAT	<ul style="list-style-type: none"> <li>Domestic hot water overheating (water temperature &gt;87°C)</li> </ul>	<ul style="list-style-type: none"> <li>Defective water sensor</li> <li>Water sensor removed from tank</li> </ul>	<ul style="list-style-type: none"> <li>Heat pump non-functional</li> <li>Automatic reset</li> </ul>	<ul style="list-style-type: none"> <li>Check that the sensor is in the right position in the tank</li> </ul>
COLD EVAP ERR.	<ul style="list-style-type: none"> <li>Heat exchanger temperature too low. Risk of ice.</li> </ul>	<ul style="list-style-type: none"> <li>No water circulating (filter clogged, underfloor circulating valve is closed)</li> <li>Incorrect connection to the underfloor heating return flow inlet (inlet/outlet reversed)</li> <li>Circuit not properly purged</li> <li>Circulator pump not functioning</li> </ul>	<ul style="list-style-type: none"> <li>Heat pump non-functional.</li> <li>Electrical back-up heats water to 43°C (38°C minimum)</li> </ul>	<ul style="list-style-type: none"> <li>Clean the filters</li> <li>Check that water is flowing freely</li> <li>Check compliance of hydraulic connection (inlet/outlet)</li> <li>Purge air at the circulator pump</li> <li>Check that the circulator pump is working properly</li> </ul>
ANTI BAC	<ul style="list-style-type: none"> <li>The anti-legionellosis cycle is not validated</li> </ul>	<ul style="list-style-type: none"> <li>Sub-draft too high</li> </ul>	<ul style="list-style-type: none"> <li>Unit on</li> </ul>	<ul style="list-style-type: none"> <li>Restart a cycle</li> </ul>
		<ul style="list-style-type: none"> <li>Set temperature too high</li> </ul>		<ul style="list-style-type: none"> <li>Reduce cycle set temperature</li> </ul>
		<ul style="list-style-type: none"> <li>Failure of the resistance</li> </ul>		<ul style="list-style-type: none"> <li>Clean the resistance</li> <li>Replace the resistance</li> </ul>
		<ul style="list-style-type: none"> <li>Electrical back-up not allowed</li> </ul>		<ul style="list-style-type: none"> <li>Authorize electrical back-up</li> </ul>
ERR.01	<ul style="list-style-type: none"> <li>Incorrect reading from the temperature sensor</li> </ul>	<ul style="list-style-type: none"> <li>The air and defrosting sensors are inverted on the electronics board</li> <li>The defrosting and water sensors are inverted on the electronics board</li> <li>The defrosting sensor is connected to the air input, the air sensor is connected to the water input, the water sensor is connected to the defrosting input</li> </ul>	<ul style="list-style-type: none"> <li>Heat pump is non-functional</li> </ul>	<ul style="list-style-type: none"> <li>Reposition the temperature sensors correctly on the main electronics board</li> </ul>
	<ul style="list-style-type: none"> <li>Incorrect reading from the defrosting sensor</li> </ul>	<ul style="list-style-type: none"> <li>The defrosting sensor is not properly connected and she is measuring air</li> </ul>		<ul style="list-style-type: none"> <li>Reposition the defrosting sensor properly in the tube</li> </ul>
	<ul style="list-style-type: none"> <li>The heat pump has run out of refrigerant fluid</li> </ul>	<ul style="list-style-type: none"> <li>There is a leak in the refrigerant circuit</li> </ul>		<ul style="list-style-type: none"> <li>Find and repair the leak before filling the refrigerant circuit</li> </ul>
	<ul style="list-style-type: none"> <li>Expansion valve is not working</li> </ul>	<ul style="list-style-type: none"> <li>The expansion valve bulbs damaged or broken due to work being carried out on the appliance, or it being in contact with a part that vibrates</li> </ul>		<ul style="list-style-type: none"> <li>Replace the expansion valve</li> </ul>
ERR.04	<ul style="list-style-type: none"> <li>The compressor is not working and safety temperature is activated</li> </ul>	<ul style="list-style-type: none"> <li>Defect in compressor</li> </ul>	<ul style="list-style-type: none"> <li>Heat pump is non-functional</li> </ul>	<ul style="list-style-type: none"> <li>Replace the compressor</li> </ul>
	<ul style="list-style-type: none"> <li>Incorrect defrosting and water sensor readings</li> </ul>	<ul style="list-style-type: none"> <li>The defrosting and water sensors are inverted on the electronics board</li> </ul>		<ul style="list-style-type: none"> <li>Reposition the temperature sensors properly on the main electronics board</li> </ul>

## 8 - WARRANTY

The tank is guaranteed against breakage for a period of five (5) years, starting from the date the appliance was activated, if the warranty form was sent back to the manufacturer. In the absence of this document, the date of manufacture will be used to determine the start date of the warranty. If the tank is broken, the whole appliance will be replaced.

The other parts are guaranteed for a period of two (2) years starting from the date the appliance was activated, if the warranty voucher was sent back to the manufacturer. In the absence of this document, the date of manufacture will be used to determine the start date of the warranty.

The appliance is guaranteed against all manufacturing defects, provided that it was installed by a qualified professional using our instruction manuals, the C15-100 standard for electrical connections and the plumbing DTU 60-1 addendum 4 for domestic water have been followed.

A defective part does not warrant the whole appliance being replaced. The warranty only extends to parts which we identify as being defective due to manufacturer defect.

If necessary, the part or product should be returned to the manufacturer but only with prior agreement from our technical department. Labour, transport, and packaging costs are the responsibility of the user. Repairs on a device will not result in compensation.

The warranty for replacement parts ends at the same time as the appliance warranty (2 years).

The warranty only applies to the appliance and its components, and excludes any part or installation external to the appliance.

Regular maintenance of the appliance by a trained professional is essential for ensuring sustained use and durability. In the absence of regular maintenance, the warranty will not apply.

If an appliance is presumed to have been the cause of any damage, the appliance and the damage must be left as they are and not tampered with until an inspection can be carried out.

### 8.1 - Limitations of warranty

#### 8.1.1 - General information

The warranty does not apply to defects or damage caused by situations or events such as:

- Misuse, abuse, negligence, improper transport or handling.
- Incorrect installation, or installation which has been carried out without following the instructions in the manual and user guide.
- Insufficient maintenance.
- Modifications or changes carried out on the appliance.
- Impacts from foreign objects, fire, earthquakes, floods, lightning, ice, hailstones, hurricanes or any other natural disaster.
- Movement, imbalance, collapse or settling of the ground or the structure where the appliance is installed.
- Any other damage which is not due to defects in the product.

The heat pump water heater is not guaranteed against:

- Variations in the colour of the appliance or damage caused by air pollution, exposure to chemical elements, or changes brought about by adverse weather conditions.
- Dirt, rust, grease, or stains which occur on the surface of the appliance.

#### 8.1.2 - Exclusion from warranty

##### 8.1.2.1 - Use

Cases (not limited to) where the warranty is void:

- The water supply being other than cold domestic water, (such as rainwater or other water from a well), or which has particularly hostile or abnormal properties which do not comply with the national regulations and current standards in effect.
- The appliance being switched on before it is filled with water.

##### 8.1.2.2 - Handling

Cases (not limited to) where the warranty is void:

- Any damage sustained by impacts or falls during handling after delivery from the factory.

- Deterioration in the condition of the appliance after handling where the instructions in the manual have not been followed.
- Damage occurring in the appliance when it has been switched on less than an hour after it has been leaning to the side or laid flat.

#### 8.1.2.3 - Placement

Cases (not limited to) where the warranty is void:

- Placing the appliance where it can be subject to frost or other adverse weather conditions.
- Non-compliance with the instructions in the manual when installing the appliance.
- Installing the appliance on a surface which cannot bear its weight when filled with water.

Costs incurred by access difficulties are not the manufacturer's responsibility.

#### 8.1.2.4 - Electrical connections

Cases (not limited to) where the warranty is void:

- Faulty electrical connection which does not comply with the current national installation standards.
- Not following the connection diagrams in the instruction manual.
- Power supply being significantly under or over the required voltage.
- Failure to comply with supply cable standards.
- Absence of, or insufficient, electrical protection throughout the appliance (fuse/ circuit-breaker, grounding, etc.).
- Damage which results from deactivating the electrical back-up aquastat and/or the heat pump.

#### 8.1.2.5 - Hydraulic connections

Cases (not limited to):

- Inverting the hot/cold water connections.
- Water pressure higher than 6 bars.
- Absence of, incorrect fitting of, or obstruction of, a pressure-relief valve.
- Not fitting the pressure-relief valve directly onto the cold water inlet of the appliance.
- Fitting a pressure-relief valve which does not comply with the current national standards (NF EN 1487).
- Installing a previously-used pressure-relief valve.
- Tampering with the pressure-relief valve.
- Abnormal levels of corrosion caused by an incorrect plumbing connection (direct contact between iron and copper) without a sleeve (cast-iron, steel or insulating).

No claim for compensation may be made for damage which has occurred as a result of not installing thermostatic mixing valves onto the appliance.

#### 8.1.2.6 - Accessories

The warranty does not cover defects resulting from:

- Installation of accessories which do not comply with manufacturer recommendations.
- Use of accessories not provided by the manufacturer.

#### 8.1.2.7 - Maintenance

Cases (not limited to) where the warranty is void:

- Not maintaining the appliance.
- Not maintaining the pressure-relief valve, resulting in excessive pressure.
- Absence of a pressure reducer.
- Not maintaining the circulator.
- Abnormal levels of limescale on heating elements or safety devices.
- Not using parts supplied by the manufacturer.
- Protective outer casing being subjected to any external damage.

# 9 - APPENDIX

## 9.1 - Wiring diagram

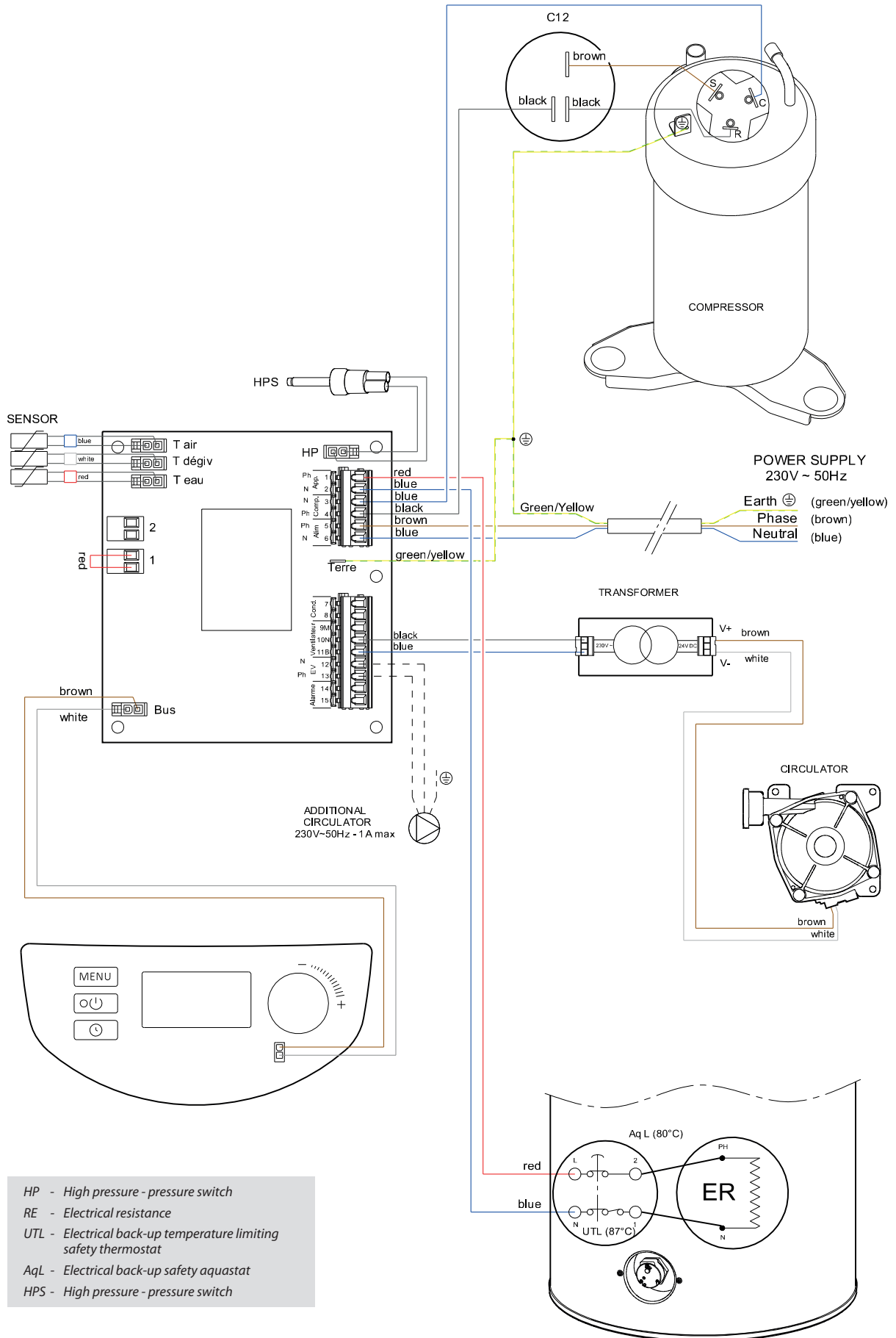

**NOTES :**



**[www.intuis.fr](http://www.intuis.fr)**

---

**Industrial and development site**

Rue de la République  
CS 40029  
80210 Feuquières-en-Vimeu

---

**Customer service**

+33 (0)9 78 45 10 26  
[service-consommateur@intuis.fr](mailto:service-consommateur@intuis.fr)  
[service-client@intuis.fr](mailto:service-client@intuis.fr)